

SOFTENERS

AQUARIUS

USER MANUAL

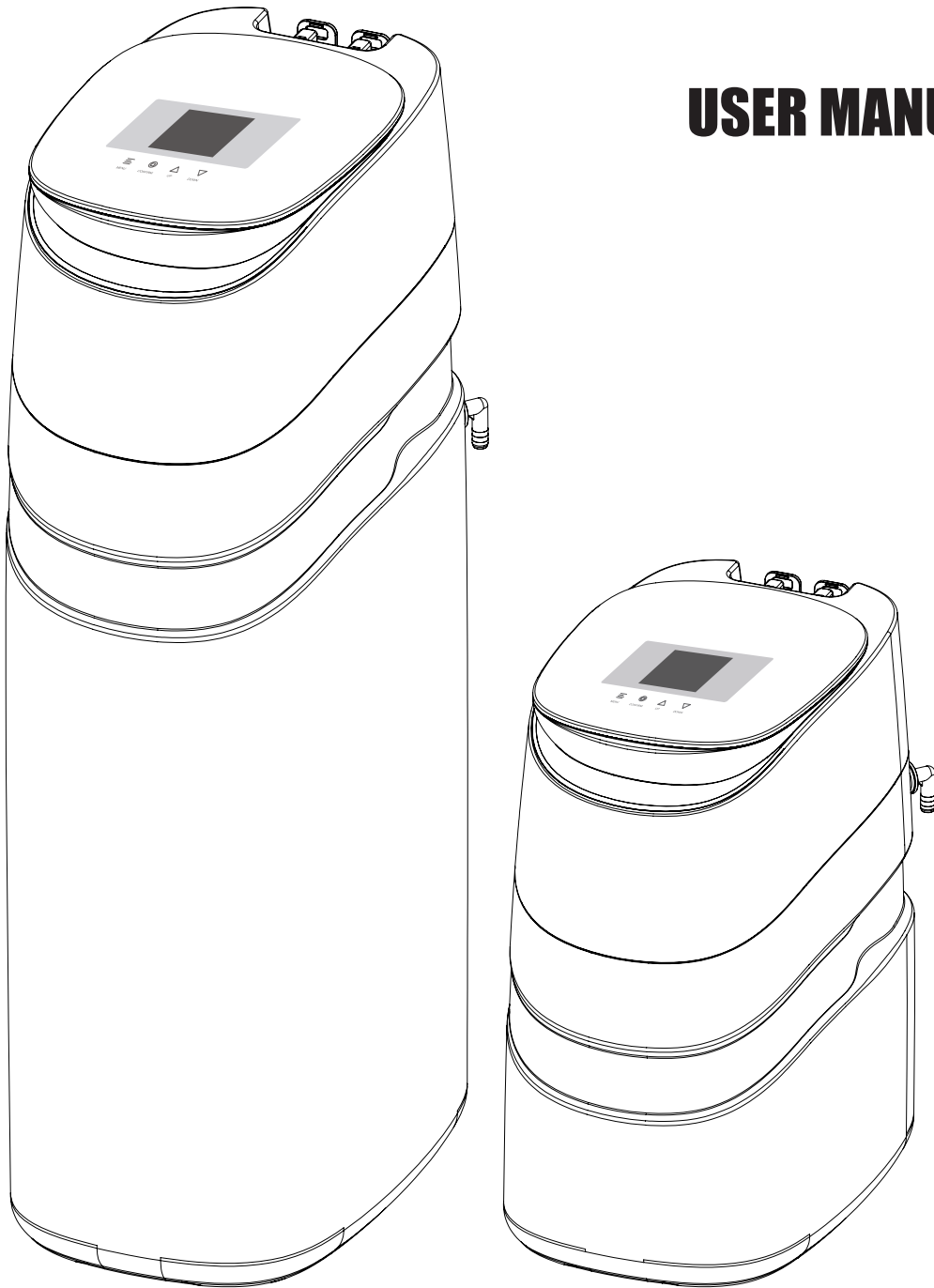

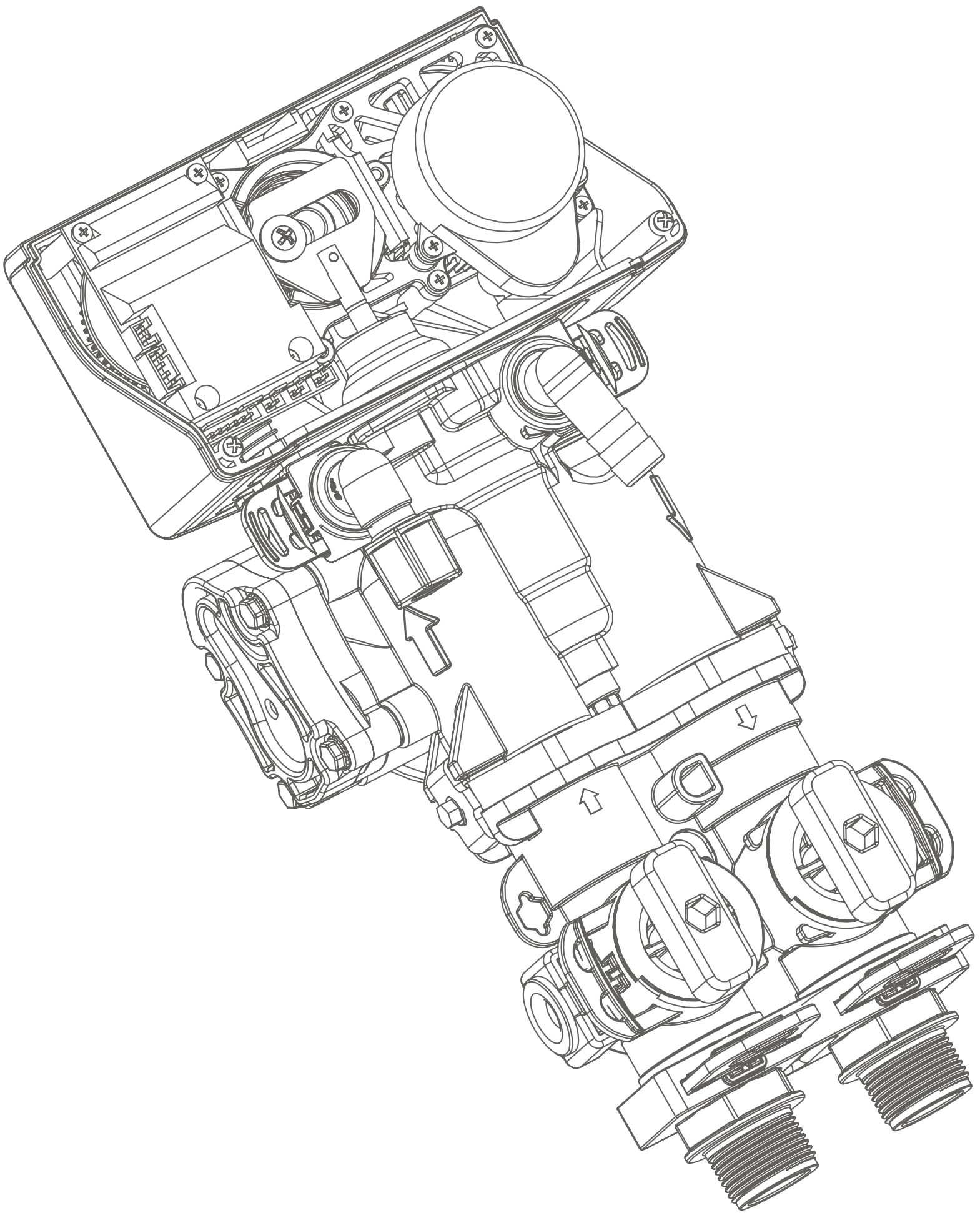

TABLE OF CONTENTS

<i>READ THIS PAGE FIRST</i>	4
<i>WATER CONDITIONER BASICS</i>	5
<i>SOFTENER SYSTEM SPECIFICATIONS</i>	6
<i>SOFTENER SYSTEM DIMENSIONS</i>	7
<i>UNPACK & INSPECT YOUR WATER SOFTENER</i>	8
<i>CHECK THE VALVE SERIAL NUMBER</i>	9
<i>CHECK THE SOFTENER SERIAL NUMBER</i>	10
<i>PARTS BREAKDOWN</i>	11
<i>PRE-INSTALLATION INSTRUCTIONS</i>	15
<i>INSTALLATION INSTRUCTIONS</i>	15
<i>WATER BYPASS</i>	17
<i>PROGRAMMING GUIDE</i>	18
<i>START-UP INSTRUCTIONS</i>	21
<i>MAINTENANCE INSTRUCTIONS</i>	23
<i>TROUBLE SHOOTING GUIDE</i>	29

READ THIS PAGE FIRST

BEFORE STARTING INSTALLATION

▶ You must read and understand the contents of this manual before installing or operating your water softener.

Personal injury or property damage could result if you fail to follow instructions in this manual.

▶ This system and its installation must comply with state and local regulations. Check with your local public works department for plumbing and sanitation codes. Local codes should be followed in the event the codes conflict with any content in this manual.

▶ This water Softener must be operated on pressures between 30 psi to 125 psi. If the water pressure is higher than 125 PSI, use a pressure reducing valve in the water supply line to the softener.

▶ This unit must be operated at temperatures between 4°C - 43°C (40°F and 110°F)

▶ Do not use this water softener on hot water supplies.

▶ Do not install this unit where it may be exposed to wet weather, direct sunlight, or temperatures outside of the range specified above.

▶ The appliance is only to be used with the power supply unit provided with the appliance.

▶ The appliance must only be supplied at safety extra low voltage corresponding to the marking on the appliance.

▶ Apply provided NSF certified lubricant to all o-rings during installation. Do not use pinched or damaged o-rings during installation.

▶ Softeners are exposed to high levels of iron, manganese, sulfur, and sediments. Damage to pistons, seals, and/or spacers within the control valve are not covered in this warranty due to the harsh environment.

▶ It is recommended to annually inspect and service the control valve. Frequent cleaning and/or replacement of piston, seals, and/or spacers may be necessary depending on how harsh the conditions are.

▶ Do not use water that is microbiologically unsafe without adequate disinfection before or after this system.

▶ This publication is based on information available when approved for printing. Continuing design refinement could cause changes that may not be included in this publication.

▶ This appliance can be used by children aged from 8 years and above and persons with reduced physical, sensory or mental capabilities or lack of experience and knowledge if they have been given supervision or instruction concerning use of the appliance in a safe way and understand the hazards involved.

▶ Children shall not play with the appliance.

▶ Cleaning and user maintenance shall not be made by children without supervision.

Atlas Filtri Engineering guarantees that your new water conditioner is built of quality material and workmanship. When properly installed and maintained, it will give years of trouble free service.

Atlas Filtri Engineering reserves the right to change the specifications referred to in this literature at any time, without prior notice.

INSTALL NOTES & SAFETY MESSAGES

Watch for the following messages in this manual:

EXAMPLE:

NOTE
Check and comply with your state and local codes. You must follow these guidelines.

EXAMPLE:

CAUTION
Disassembly while under pressure can result in flooding.

EXAMPLE:

 **WARNING**
Electrical Shock Hazard! Unplug the unit before removing the cover or accessing any internal control parts.

WATER CONDITIONER BASICS

WHAT IS HARD WATER AND HOW IT IS SOFTENED

All of the fresh water in the world originally falls as rain, snow, or sleet. Surface water evaporates and is drawn upward by the sun, forming clouds. Then, nearly pure and soft as it starts to fall as rain. It begins to collect impurities as it passes through smog and dustladen atmosphere back to the ground. And as it seeps through soil and rocks it gather hardness, rust, acid, unpleasant tastes and odors.

Water hardness is caused primarily by limestone dissolved from the earth by the rainwater. Because of this, in earlier times, people who wanted soft water collected rainwater from roofs in rain barrels and cisterns before it picked up hardness from the earth.

Some localities have corrosive water. A softener cannot correct this problem. This softener has warranty disclaims of liability for corrosion of plumbing lines, fixtures or appliances.

Iron is a common water problem. The chemical/physical nature of iron found in natural water supplies is exhibited in four general types:

1. DISSOLVED IRON—Also called ferrous or “clear water” iron. Dissolved iron is soluble in water and is detected by taking a sample of the water to be treated in a clear glass. The water in the glass is initially clear, but on standing exposed to the air, it may gradually turn cloudy or colored as it oxidizes. This type of iron can be removed from the water by the same ion exchange principle that removes the hardness elements, calcium and magnesium.

2. PARTICULATE IRON—Also called ferric or colloidal iron. This type of iron is an undissolved particle of iron. A filtering treatment will be required to remove this type of iron. A softener will remove larger particles, but the particles may not be washed out in regeneration effectively and will eventually foul the ion exchange resin.

3. ORGANIC BOUND IRON—This type of iron is strongly attached to an organic compound in the water. The ion exchange process alone cannot break this bond down and the softener will not remove this type of iron.

4. BACTERIAL IRON—This type of iron is protected inside a bacteria cell. Like the organic bound iron, it is not removed by a water softener.

It's important that when a softener is removing both hardness and dissolved iron, it must regenerate more frequently than it normally would for just hardness. Many factors and formulas have been used to determine this frequency. It is recommended that the softener be regenerated when it has reached 50–75% of the calculated hardness alone capacity. This will minimize the potential for bed fouling.

Regular resin bed cleaning is needed to keep the bed from coating with iron if you are operating a water softener on clear water iron. Even when operating a softener on water with less than the maximum of dissolved iron, regular cleanings should be performed. Clean every six months or more often if iron appears in your conditioned water supply. Use resin bed cleaning compounds carefully following the directions on the container.



CAUTION

DO NOT USE WATER FILTERED THROUGH THIS SOFTENER WHERE THE WATER IS MICROBIOLOGICALLY UNSAFE OR THE WATER IS OF UNKNOWN QUALITY. THE WATER MUST BE DISINFECTED BEFORE OR AFTER THE UNIT.

SOFTENER SYSTEM SPECIFICATIONS

BNT850SE UF VALVE

Performance Data Sheet and Specifications		
Model	CS16H-1017	CS16H-1035
Control System	BNT-850SE UF Control Valve	
Regeneration Type	UP Flow	
Integrated Meter in Bypass	Yes	Yes
Hardness Removal(6 lb/cf Salt Dosage)	704 Gram	1408 Gram
Media Loaded	Yes	Yes
Resin Quantity	12.5 L	25 L
Resin Type	Extremely High Capacity Ion Exchange Resin - Exclusive	
Tank Size	10x17	10x35
Salt Storage Capacity	24 Kg	64 Kg
Recommended Service Flow Rate	6.7 L/M	13 L/M
Recommended Cycle Settings		
Backwash Duration Setting	1 Min	3 Min
Brine Duration Setting	34 Min	87 Min
Rinse Duration Setting	3 Min	5 Min
Refill Duration Setting	4.4 Min	8.8 Min
Salt Used - Per Regeneration(6 lb/cf Salt Dosage)	1.2 Kg	2.4 Kg
Water Used - Regeneration	60 L	132 L
Flow Rate (Only valve)		
Continuous Flow Rate @ 15 psi Pressure Drop	4700L/H	
Peak Flow Rate @ 25 psi Pressure Drop	6100L/H	
Back Wash Flow Rate@ 25 psi Pressure Drop	1800L/H	
Shipping Weight	25 Kg	45 Kg
Pipe Size	3/4" or 1"	
Plumbing Connections	Includes 3/4" & 1" Straight Fittings	
Electrical Requirements	Input 110V-120V / 220-240V AC 50/60Hz	
	Output 12V AC 650mA	
Water Temperature	3 ~ 38 °C	
Water Pressure	0.14 ~ 0.86MPa	

- Capacities of conditioners may deviate from the chart above depending on flow rates and raw water conditions.
- Changing salt settings from factory setting may require changing injector sizes to achieve stated capacities.
- Hardness removal is based on standard salt setting(6lbs/cf).
- Iron content must not exceed 1 ppm. Beyond 1 ppm an iron softener must be used.
- Do not subject the unit to freezing temperatures.
- Do not use water that is microbiologically unsafe without adequate disinfection before or after the system.
- The manufacturer reserves the right to make product improvements which may deviate from the specifications and descriptions stated herein, without obligation to change previously manufactured products or to note the change.

SOFTENER SYSTEM DIMENSIONS

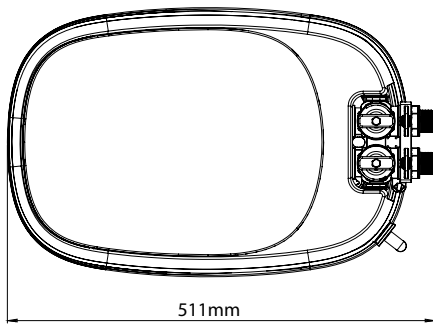
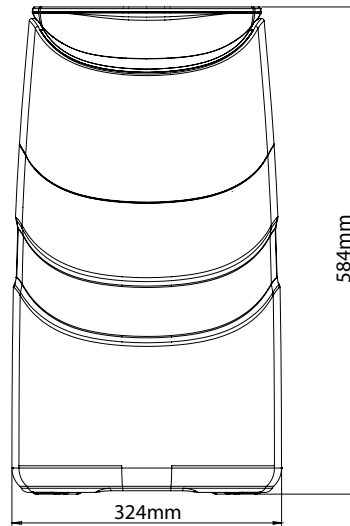
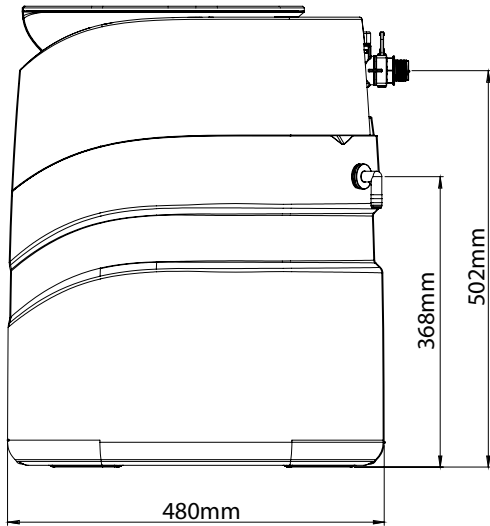

1017 TANK

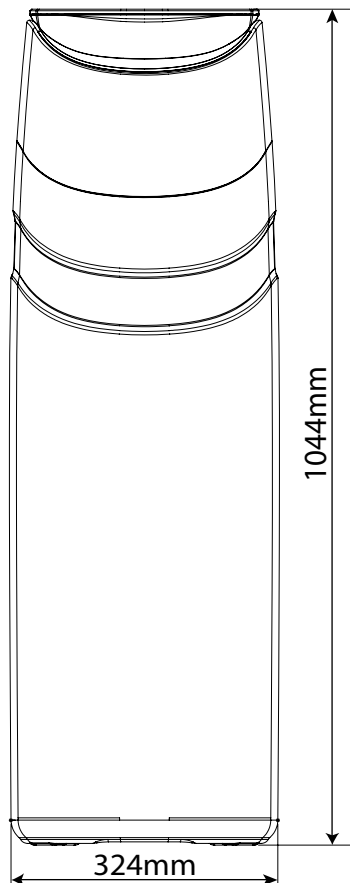
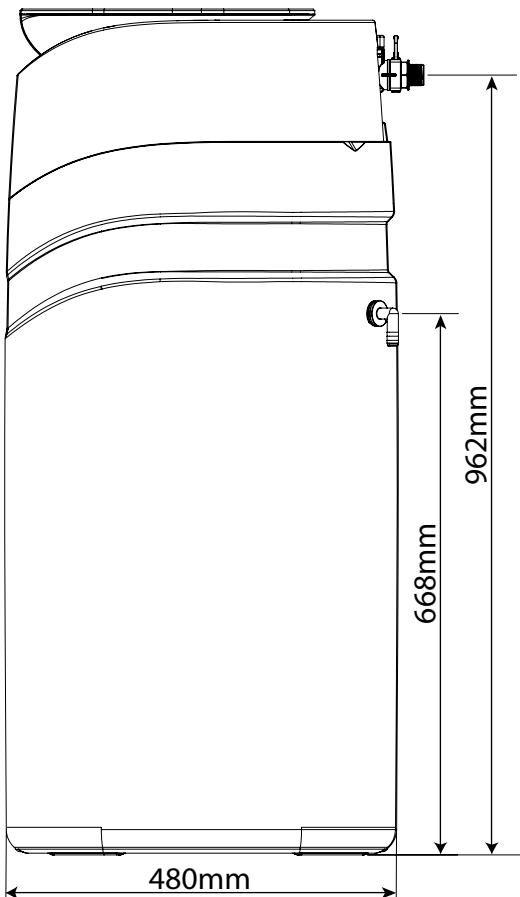

1035 TANK

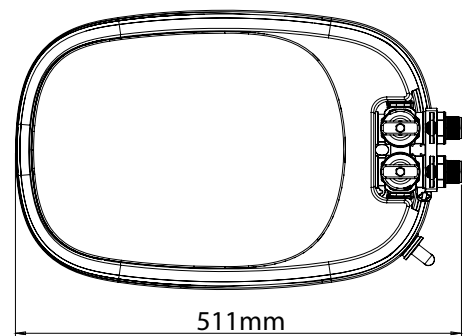

UNPACK & INSPECT YOUR WATER SOFTENER

Inspect the water softener for any shipping damage. If damage is found, notify the transportation company and request a damage inspection. Damage to cartons should also be noted.

Handle the softener unit with care. Do not drop the unit or set on sharp, uneven projections on the floor. Do not turn the softener unit upside down.

NOTE

IF THERE IS A SEVERE LOSS IN WATER PRESSURE WHEN THE SOFTENER UNIT IS INITIALLY PLACED IN SERVICE, THE SOFTENER TANK MAY HAVE BEEN LAID ON ITS SIDE DURING TRANSIT. IF THIS OCCURS, BACKWASH THE SOFTENER TO "RECLASSIFY" THE MEDIA.

The manufacturer is not responsible for damages in transit. Small parts, needed to install the Softener, are in a parts box. To avoid loss of the small parts, keep them in the parts bag until you are ready to install.

ACCESSORIES CONTENTS :

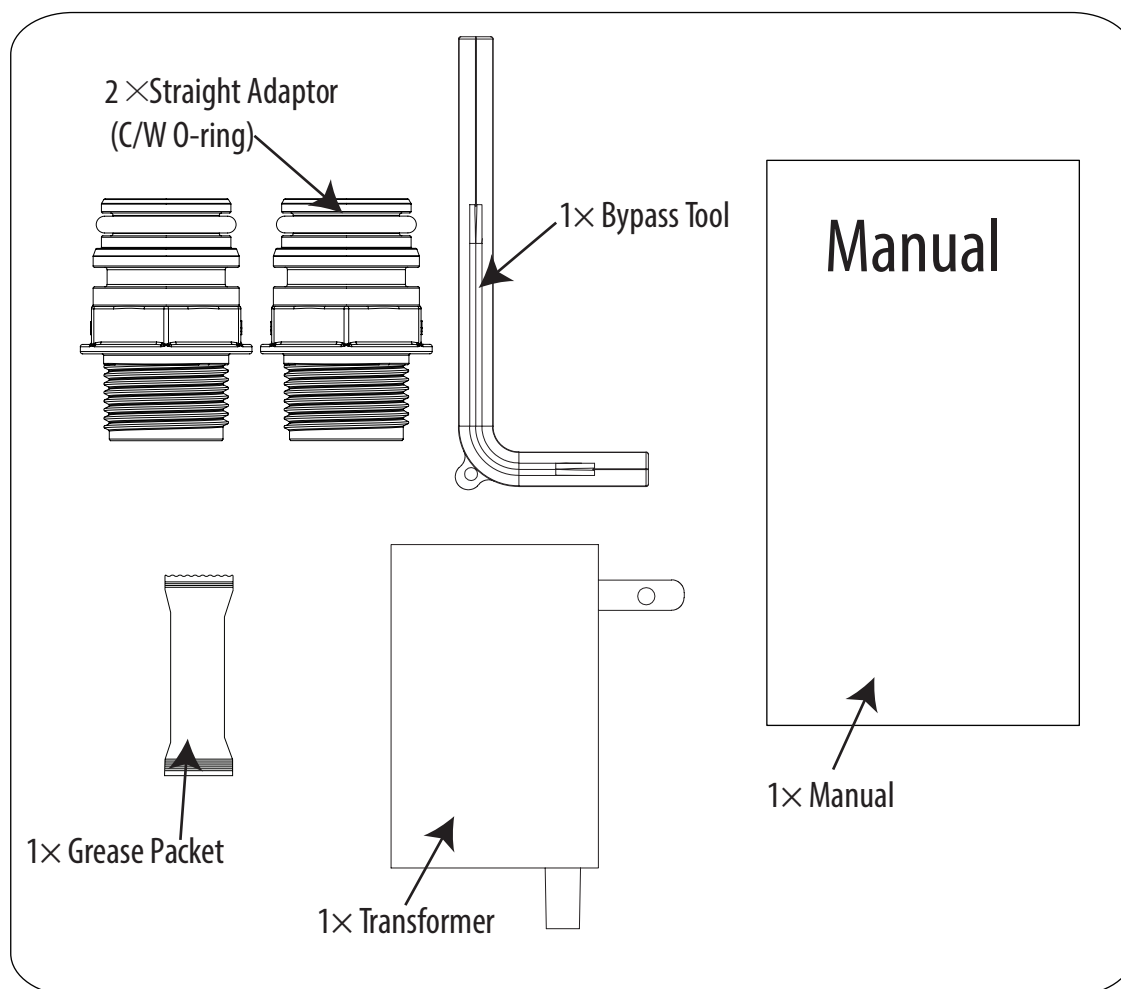

CHECK THE VALVE SERIAL NUMBER

Check to make sure the valve type matches what you ordered. The valve configuration sticker will show the injector, BLFC and DLFC size. The valve model sticker shows model, hardware/software version, serial # and batch code of the control valve. Serial numbers are important for troubleshooting.

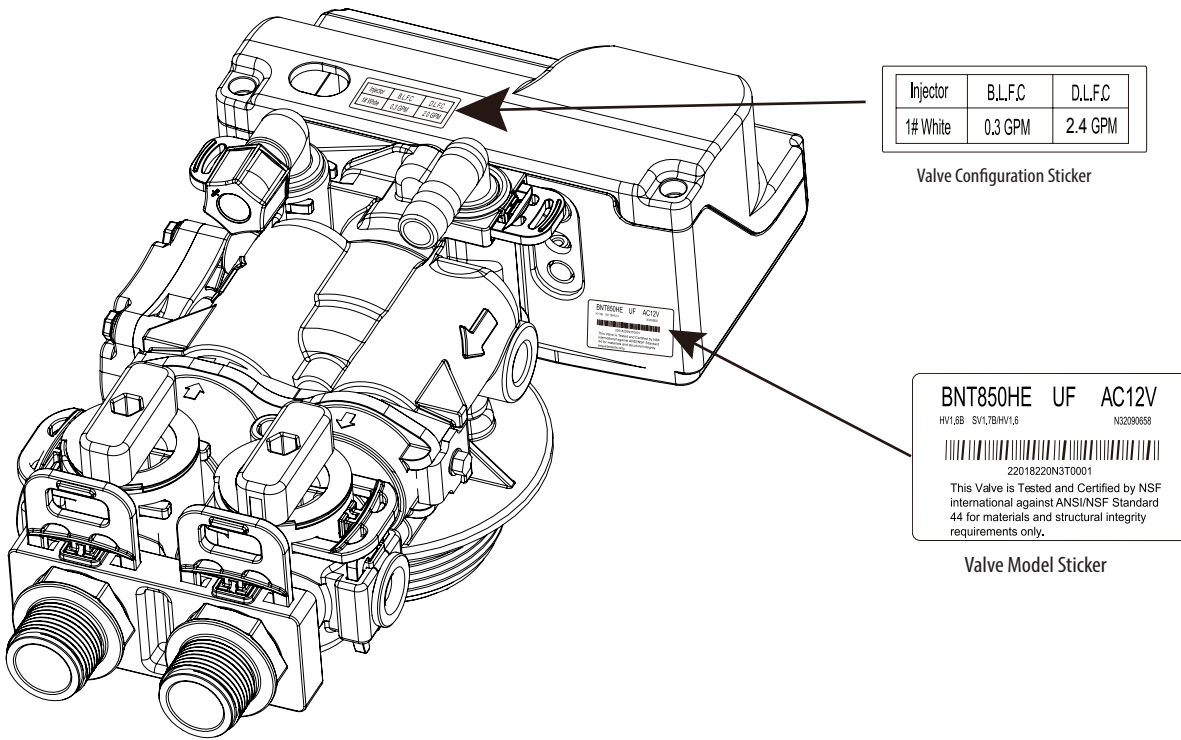

VALVE SERIAL NUMBER:

22018220N730001

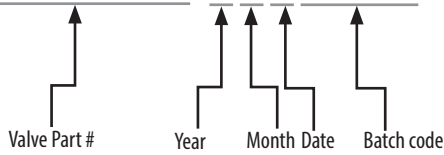

(22018220): Valve part #

(N)YEAR: "N" stand for year 2017, "M" stand for year 2016, "L" stand for year 2015, "K" stand for year 2014...

(7)MONTH: 1(JAN), 2(FEB), 3(MAR), 4(APRIL), 5(MAY), 6(JUNE), 7(JULY), 8(AUG), 9(SEP), A(OCT), B(NOV), C(DEC)

(3)DATE: 1 2 3 4 5 6 7 8 9 (A)10 (B)11 (C)12 (D)13 (E)14 (F)15 (G)16 (H)17 (I)18 (J)19 (K)20 (L)21 (M)22 (N)23 (O)24 (P)25 (Q)26 (R)27 (S)28 (T)29 (U)30 (V)31

(0001): Batch code

CHECK THE SOFTENER SERIAL NUMBER

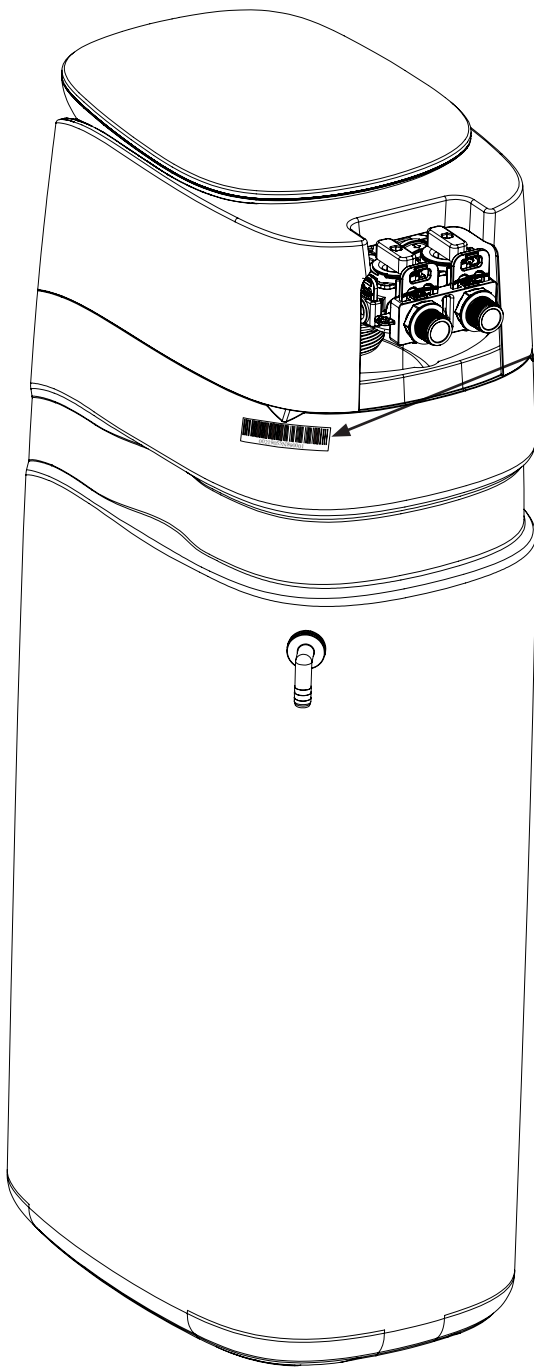

00299407N890001

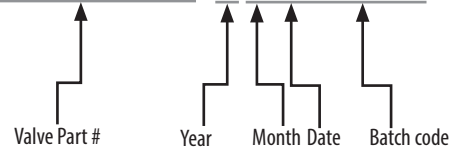

(00299407): Softener part #

(N)YEAR: "N" stand for year 2017, "M" stand for year 2016, "L" stand for year 2015, "K" stand for year 2014...

(8)MONTH: 1(JAN), 2(FEB), 3(MAR), 4(APRIL), 5(MAY), 6(JUNE), 7(JULY), 8(AUG), 9(SEP), A(OCT), B(NOV), C(DEC)

(9)DATE: 1 2 3 4 5 6 7 8 9 (A)10 (B)11 (C)12 (D)13 (E)14 (F)15 (G)16 (H)17 (I)18 (J)19 (K)20 (L)21 (M)22 (N)23 (O)24 (P)25 (Q)26 (R)27 (S)28 (T)29 (U)30 (V)31

(0001): Batch code

PARTS BREAKDOWN

SOFTENER PARTS LIST

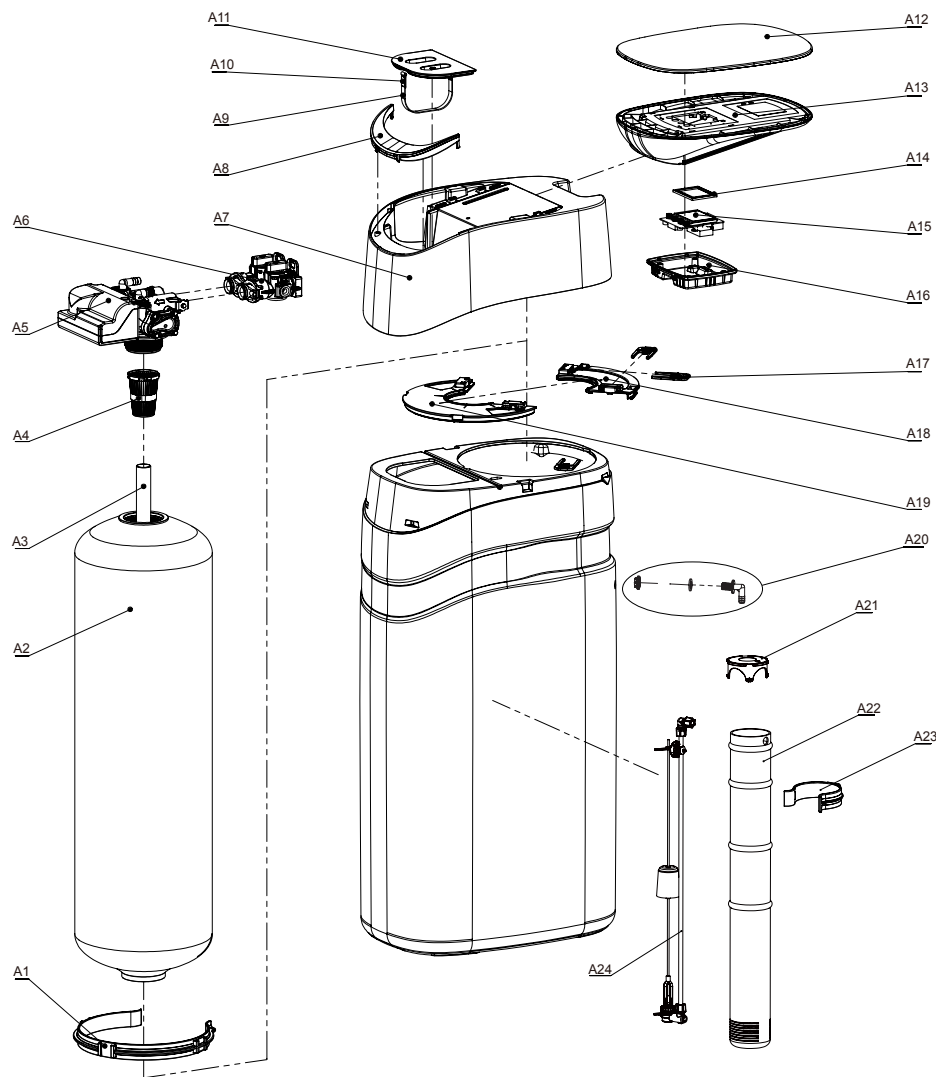

No.	Part #	Description	Qty
A1	21710110	Pressure Tank Clamp	1
A2	07591035	1035 Pressure Tank	1
	07501017	1017 Pressure Tank	1
A3	02030016	Distribution Assy-1035	1
	02030018	Distribution Assy-1017	1
A4	07060009	Top Cone	1
A5	22018603	Control Valve Assy	1
A6	22053013B	Bypass Valve Assy	1
A7	07030498	Softener Cover(White)	1
A8	07030499	Softener Trim Cover(Green)	1
A9	07080032	Ribbon	1
A10	06055016	Metal Buckle	2
A11	07030501	Softener Salt Lid(White)	1
A12	50030186	Glass Control Panel	2
A13	07030500	Sliding Cover	1
A14	05040120	Display Seal	1
A15	05030028D	Controller Display PCB	1
A16	05030044	Controller Back Cover(Black)	1
A17	21709003	Secure Clip	2
A18	07050093	Snap-gauge Small(Black)	1
A19	07050092	Snap-gauge Big(Black)	1
A20	02170008M	Overflow assy	1
A21	07030098	Brine Well Cap	1
A22	07030055W	0435 Brine Well	1
	07030054W	0417 Brine Well	1
A23	21710104B	Brine Well Clamp	1
A24	07010014G	0435 Brine Valve Assy	1
	07010013G	0417 Brine Valve Assy	1

VALVE BODY PARTS LIST

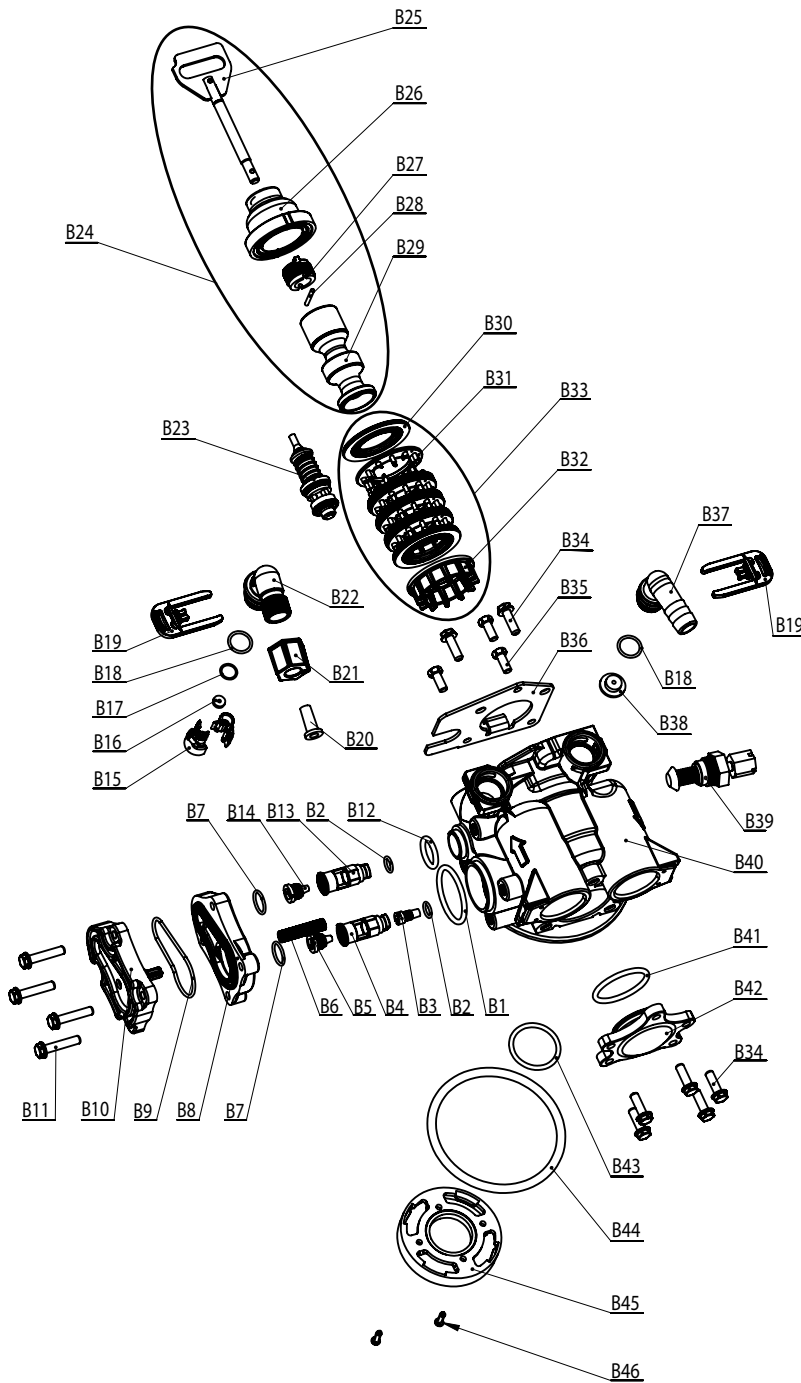

No.	Part #	Description	Qty
B1	05031022	Big O-ring of Injector Cover	1
B2	05031020	Small O-ring of Injector Holder	2
B3	30040096M	#0000 Black Injector Throat(Optional)	1
B4	05031012M	Injector Holder	1
B5	30040097M	#0000 Black Injector Nozzle(Optional)	1
B6	05056103	Screen	1
B7	05031019	Big O-ring of Injector Holder	2
B8	05031003M	85HE Injector Cover	1
B9	05031018	O-ring on Injector Cover	1
B10	05031004M	85HE Injector Cover Cap	1
B11	05031027	Screws on Injector Cover Cap	4
B12	05031021	Small O-ring of Injector Cover	1

B13	05031013M	Injector Holder Plug	1
B14	05056156	Injector Nozzle Plug	1
B15	05031010M	BLFC Holder	2
B16	05056206M	BLFC(0.2GPM)(Optional)	1
B17	05031033	O-ring of BLFC Holder	1
B18	05056134	O-ring of Brine Line Elbow	2
B19	05056172N	Secure Clip-S	2
B20	30110004M	Tube Insert	1
B21	21389033M	Brine Line Elbow Nut	1
B22	30020013M	Brine Line Elbow	1
B23	05056180M	Brine Valve Injector Stem Assy	1
B24	02170101	Piston Assembly-85HE Valve(UF)	1
B25	05031032	Piston Rod-85HE Valve	1
B26	02170233	End Plug-85HE Valve	1
B27	05031014	Piston Retainer-85HE Valve	1
B28	05056097	Piston Pin	1
B29	05057002	UP Flow Piston-85HE Valve	1
B30	05056073	Seal-85HE Valve	1
B31	05056204M	Spacer-85HE Valve	8
B32	05031005	Bottom Spacer-85HE Valve	1
B33	02170102	Seals and Spacers Assembly	1
B34	05056508	Valve Body Connect Screws	7
B35	05056087	End Plug Retainer Screws	3
B36	05056047	End Plug Retainer	1
B37	05010082M	Drain Elbow	1
B38	05056186	DLFC(2.4GPM)(Optional)	1
B39	02170013M	Mixing Valve Assy	1
B40	05031002B	85HE Valve Body	1
B41	05030013	O-ring on 85HE Side Cover	1
B42	05030004	85HE Side Cover	1
B43	26010103	Distributor O-ring	1
B44	05056063	Tank Mouth O-ring	1
B45	07060007	Valve Bottom Connector	1
B46	05056084	Screw on Valve Bottom Connector	2

POWER HEAD PARTS LIST

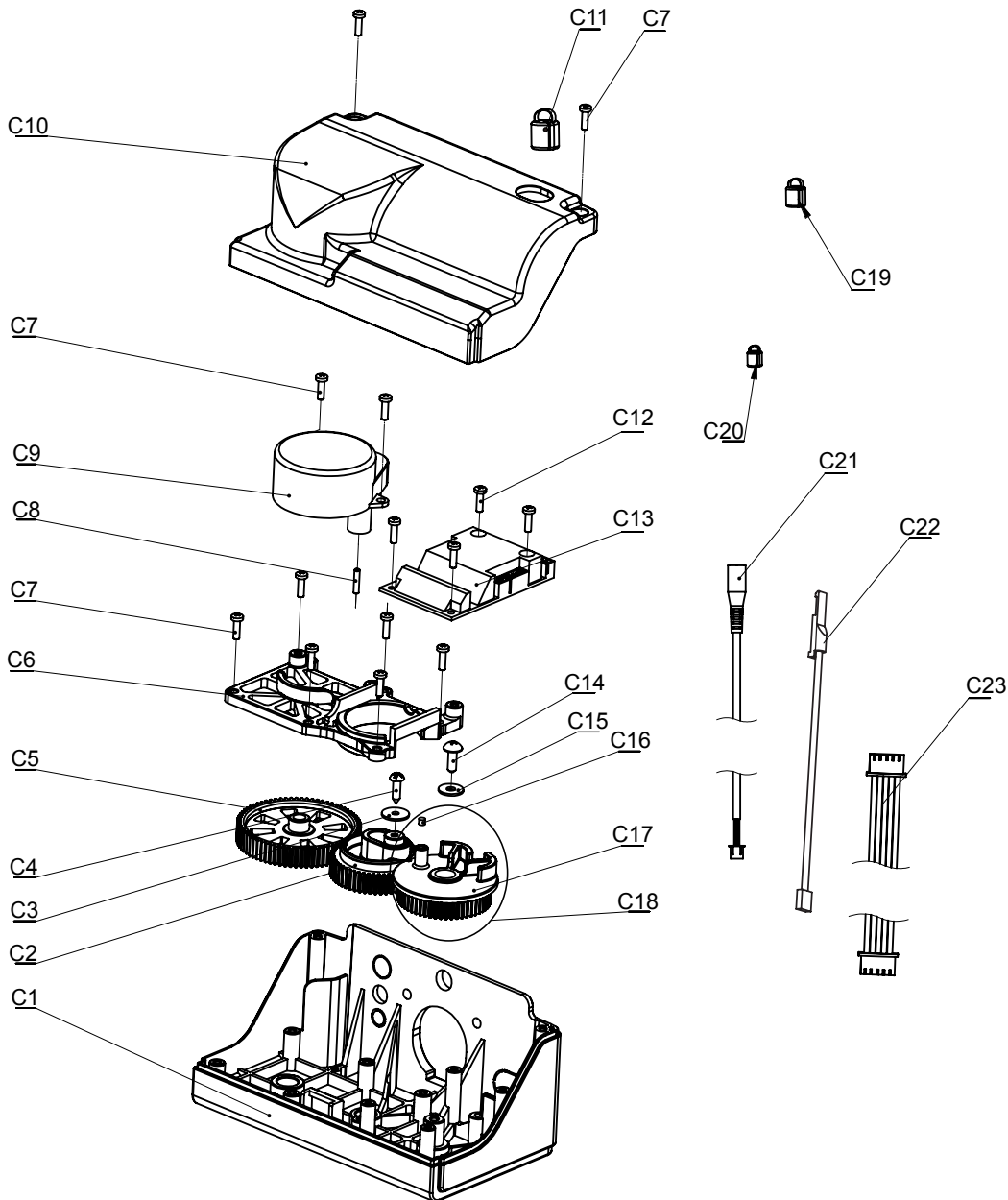

No.	Part #	Description	Qty
C1	05030005	Bnt85HE Base	1
C2	05031008M	85HE Main Gear	1
C3	05056139	Washer on Main Gear	1
C4	13000426	Screw on Main Gear	1
C5	05030009M	Motor Gear	1
C6	05031006	Mounting Plate	1
C7	05056084	Screws on Mounting Plate	10
C8	05056098	Motor Pin	1
C9	05056550	Motor	1
C10	05030024	85HE Cover	1
C11	05056013	Communication Cable Clip	1
C12	05010037	Screws on PCB	4
C13	05031025	85HE- PCB(UF)	1
C14	05056166B	Screw on Brine Gear	1
C15	05056141B	Washer on Brine Gear	1

C16	05010023	Magnet	1
C17	05031009	85HE Brine Gear(UF)	1
C18	05031009N	Brine Gear(UF)(C/W magnet)	1
C19	05010046	Meter Cable Clip	1
C20	05010035	Power Cable Clip	1
C21	05010029B	Power Cable	1
C22	05010031	Meter Cable	1
C23	12100024	Communication Cable	1

BYPASS PARTS LIST

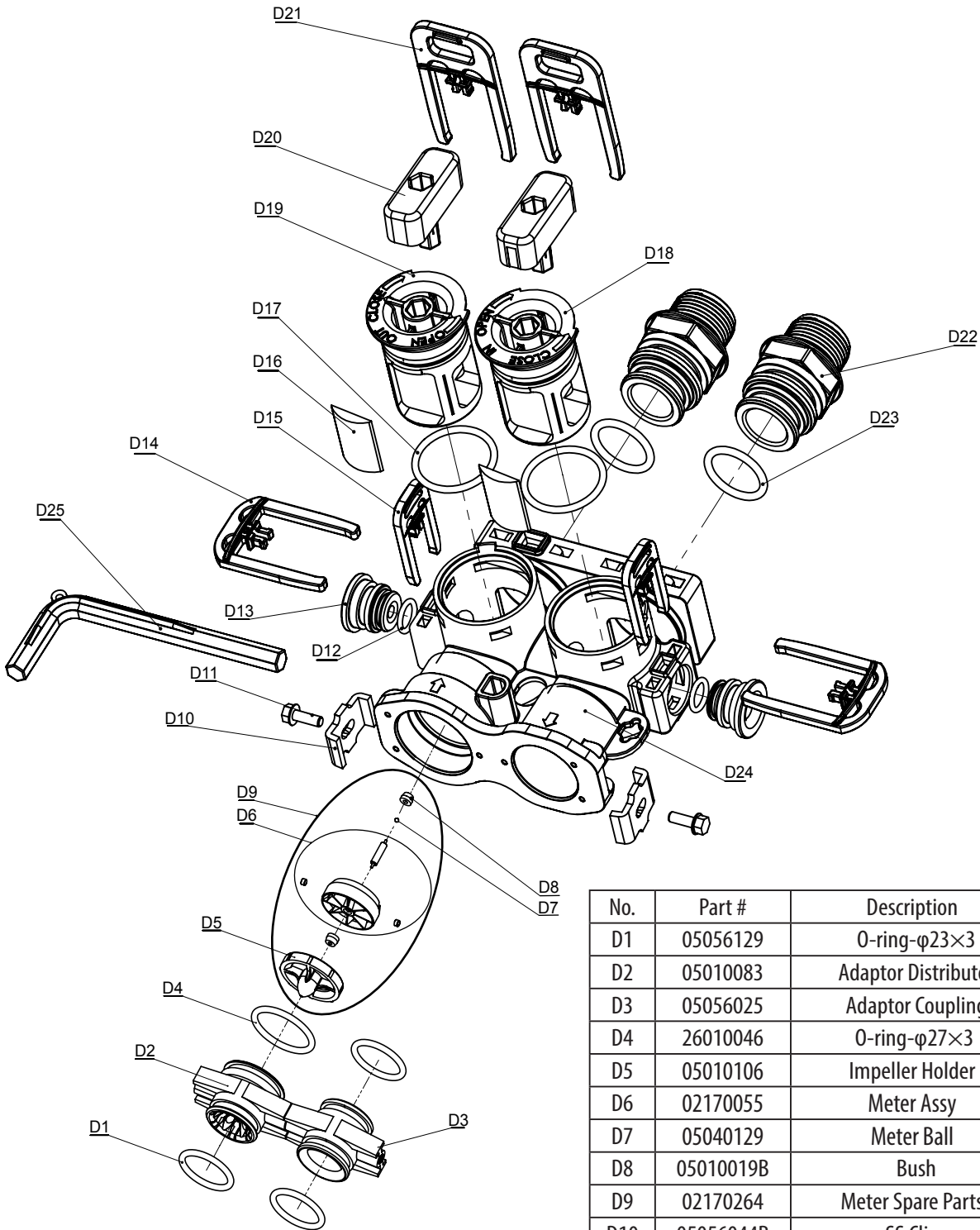

No.	Part #	Description	Qty
D1	05056129	O-ring-φ23×3	3
D2	05010083	Adaptor Distributor	1
D3	05056025	Adaptor Coupling	1
D4	26010046	O-ring-φ27×3	1
D5	05010106	Impeller Holder	1
D6	02170055	Meter Assy	1
D7	05040129	Meter Ball	1
D8	05010019B	Bush	2
D9	02170264	Meter Spare Parts	2
D10	05056044B	SS Clip	2
D11	13000327	Screw M4×12	2
D12	05056134	O-ring(12×2)	2
D13	05056146	Bypass Plug	2
D14	21709004	Shaft Clip	2
D15	05056172N	Plug Clip	2
D16	05056149B	Shaft Seal	2
D17	05030013	O-ring(30×2.65)	2
D18	05056213	Bypass Shaft(Inlet)	1
D19	05056214	Bypass Shaft(Outlet)	1
D20	05056220	Bypass Knob	1
D21	21709003	Connector Clip	2

D22	21319006	Connector 3/4" Straight	2
D23	26010143	O-ring(22.4×3.55)	2
D24	05056212	063 Bypass Body	1
D25	70020007M	Bypass Tool	1

PRE-INSTALLATION INSTRUCTIONS

Contact your local distributor to have a complete water analysis and check your water hardness on your water supplier, this will keep your conditioner in proper working.

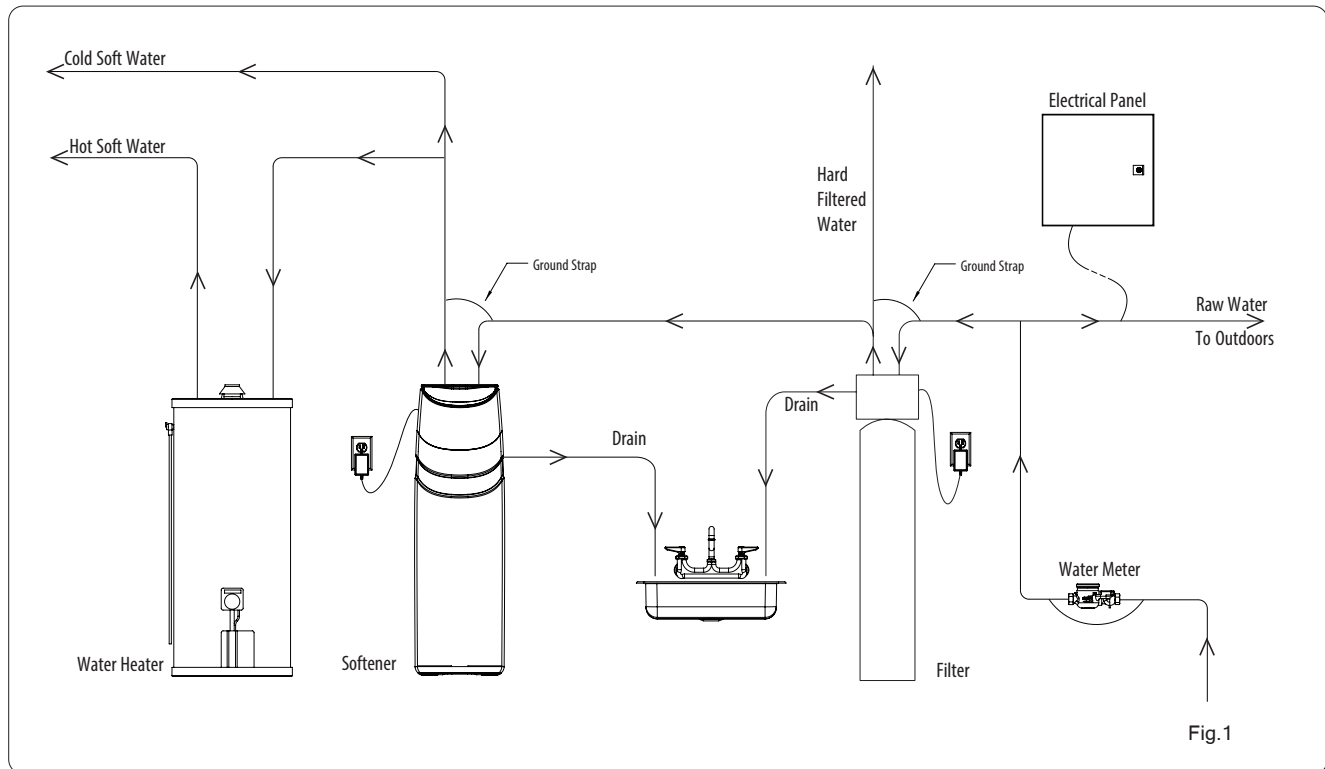

NOTE

YOU MUST FOLLOW ALL GOVERNMENT CODES AND REGULATIONS GOVERNING THE INSTALLATION OF THESE DEVICES.

INSTALLATION INSTRUCTIONS

DETERMINE THE CORRECT LOCATION OF THE WATER CONDITIONING EQUIPMENT

Select the location of your softener with care. Review the various conditions below to determine a proper location:

1. Locate as close as possible to the water supply source.
2. Locate as close as possible to a floor or laundry tub drain.
3. Locate in correct relationship to other water conditioning equipment (See Fig. 1).
4. Softener should be located in the supply line before the water heater. Temperatures above 120°F damage softeners.
5. Do not install a softener in a location where freezing temperatures occur. Freezing may cause permanent damage to this type of equipment and will void the factory warranty.
6. Allow sufficient space around the unit for easy servicing.
7. Determine if additional plumbing is required if your water source is a community water supply, a public water supply or you wish to bypass water used for a geothermal heat pump, lawn sprinkling, out-buildings or other high demand applications, refer to Fig. 1).
8. Keep the softener out of direct sunlight. Heat build up from direct sunlight may soften and distort plastic parts.

TOOLS REQUIRED FOR INSTALLATION:

- ▶ Two adjustable wrenches.
- ▶ Additional tools may be required if modifications to home plumbing are required.
- ▶ Use copper, brass, or PEX pipe and fittings.
- ▶ Some codes may also allow PVC plastic pipe. Refer to local codes.
- ▶ Always install the included bypass valve, or 3 shut-off valves. Bypass valves let you turn off water to the softener for repairs, but still have water in the house pipes.
- ▶ 5/8" OD drain line is needed for the drain.

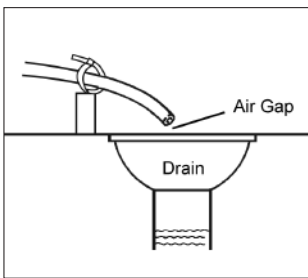
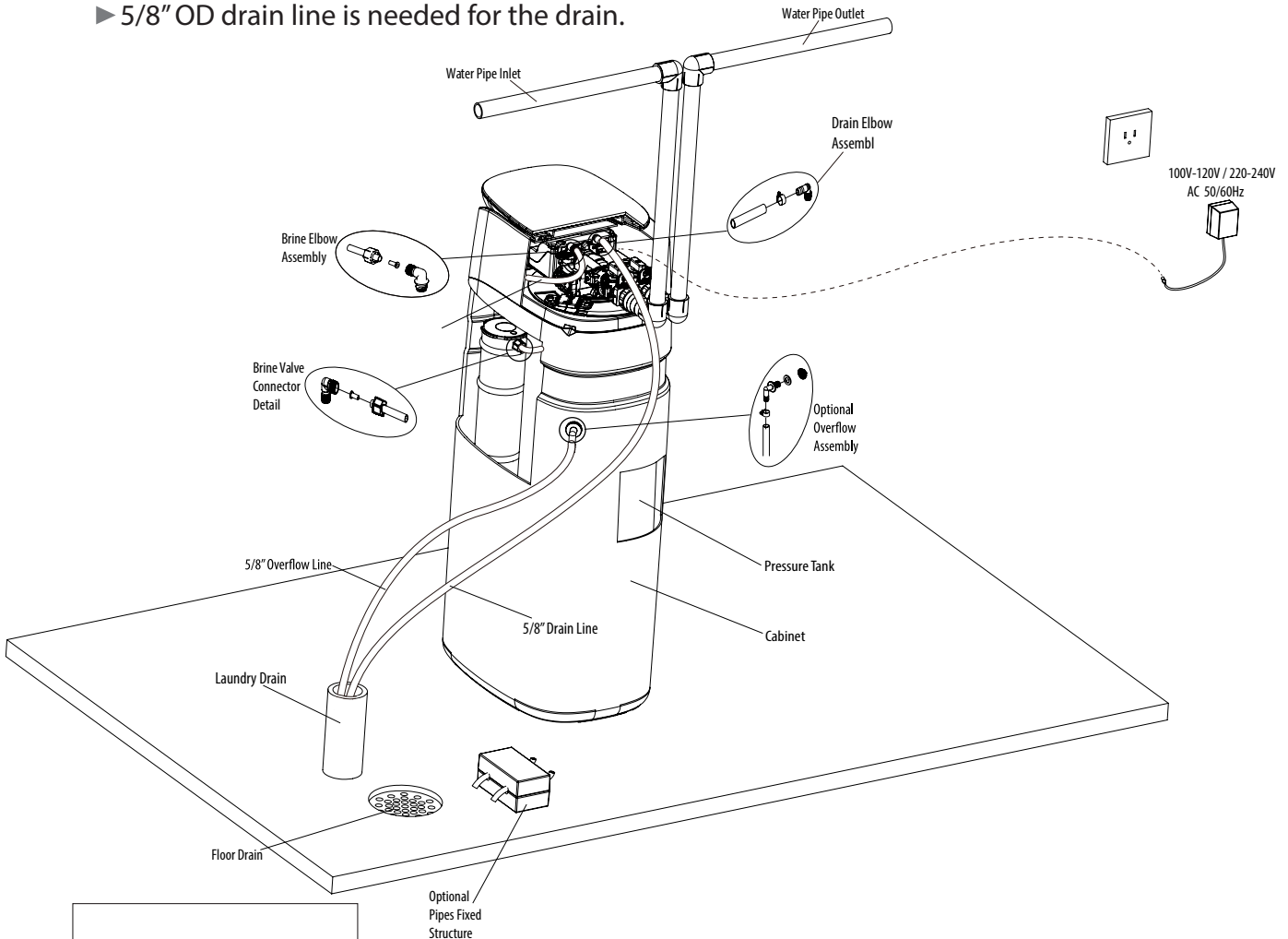

⚠ CAUTION

THE WASTE CONNECTION OR DRAIN OUTLET SHALL BE DESIGNED AND CONSTRUCTED TO PROVIDE AN AIR-GAP TO THE SANITARY WASTE SYSTEM OF 2 PIPE DIAMETERS OR 1 INCH (25MM). (WHICHEVER IS LARGER)

⚠ CAUTION

NEVER INSERT THE DRAIN LINE DIRECTLY INTO A DRAIN, SEWER LINE, OR TRAP. ALWAYS ALLOW AN AIR GAP BETWEEN THE DRAIN LINE AND THE WASTE WATER. THIS WILL PREVENT THE POSSIBILITY OF SEWAGE BEING BACK-SIPHONED INTO THE CONDITIONER.

NOTE PERFORM ALL PLUMBING ACCORDING TO LOCAL PLUMBING CODES.

WATER BYPASS

In case of an emergency such as softener maintenance, you can isolate your water softener from the water supply using the bypass valve located at the back of the control. In normal operation the bypass is open with the ON/OFF knobs in line with the INLET and OUTLET pipes. To isolate the softener, simply rotate the knobs to the BYPASS position.

You can use your water related fixtures and appliances as the water supply is bypassing the softener. However, the water you use will be hard. To resume treated service, open the bypass valve by rotating the knobs to SERVICE position.

Please make sure bypass knobs are completely open otherwise the unsoftened water could bypass through the valve.

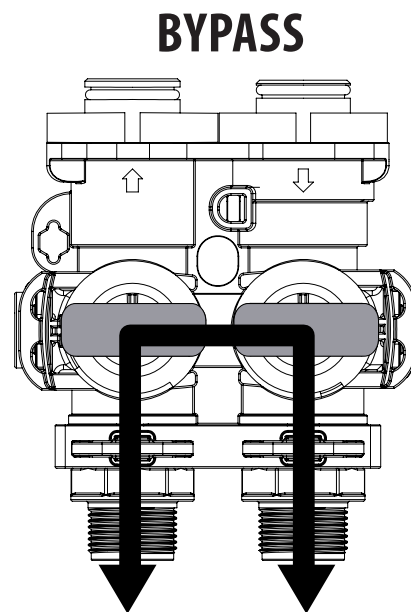
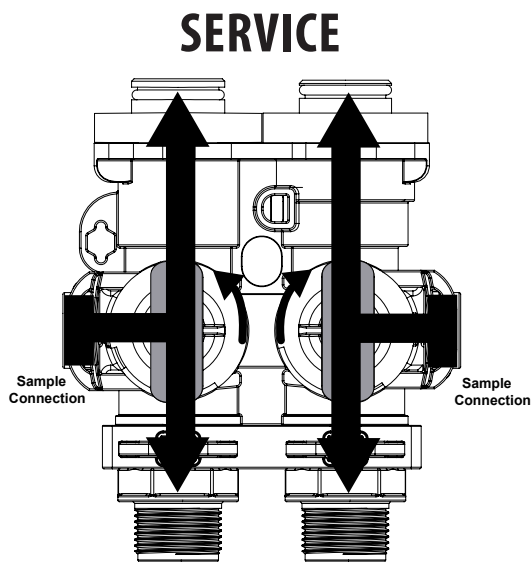

BYPASS NOT ALLOWED POSITION

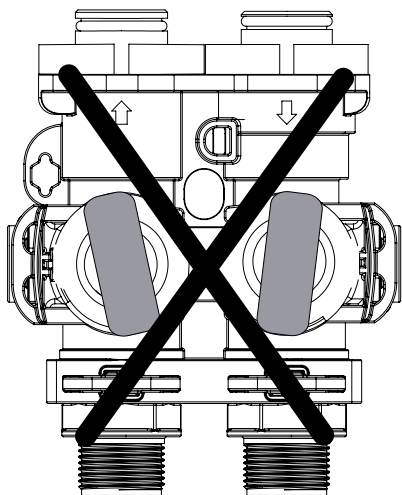

NOTE

Please make sure bypass knobs are completely open otherwise the unsoftened water could bypass through the valve.

PROGRAMMING GUIDE

FAMILIARIZE WITH KEY PAD CONFIGURATION

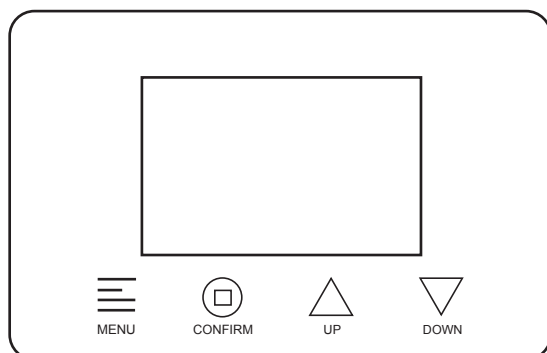

MENU

This function enters the basic set up information required at the time of installation.



CONFIRM

This function is to press and select one item to change and accepts the values if changed.



UP DOWN

This function is to scroll up or down the programming items and increase or decrease the values of the settings while in the programming mode.

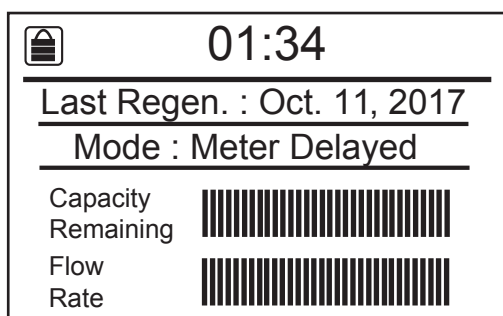

System Standby Display:

Current Time, Last Regen. Time, Regen. Mode will be displayed on the screen.

FAMILIARIZE WITH DISPLAY ICON

MAIN MENU DISPLAY



ADVANCED SETTINGS DISPLAY

System Regenerate Based On Automatic Calculation:

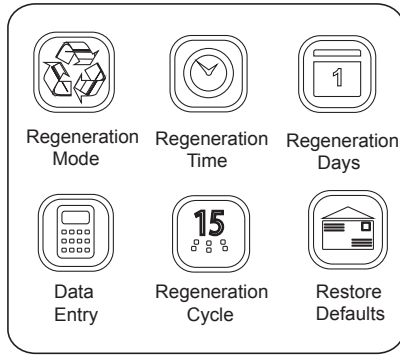



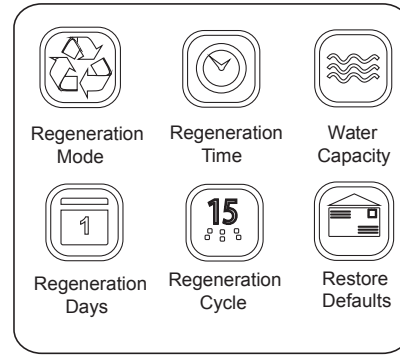

































System Regenerate Based On Manual Settings:



PARAMETER		DESCRIPTION
Time		Current Time setting.
Region		Unit of measure the system used, METRIC(litre)and US(gallon) options are available now.
Language		System language used on the valve display, 10 different language options in total for your choice. English, Spanish, French, Russian, Turkey, German, Polish, Italian, Dutch and Chinese.
Water Hardness		This value is water hardness of the raw water supply. It is used to calculate the system capacity.
People Number		Number of people in the household and the calculated reserve capacity. When remaining reaches reserve capacity a regeneration will be scheduled.
Holiday Mode		When set to ON, the system will perform a Backwash and a Rinse if there is no water flow detected after 7 days. The Backwash and Rinse duration can be set in the Regeneration Cycle.
Regen. Mode	Calendar Clock	The unit will initiate a regeneration at the next pre-set regeneration time based on the interval of days between regeneration days.
	Meter Immediately	The unit will initiate a regeneration immediately after the system capacity remaining reaches zero.
	Meter Delayed	When the system capacity remaining reaches zero, the system will initiate a regeneration at the next pre-set regeneration time.
	Meter Override	When the volume remaining goes below the system capacity, the system will regenerate at the regen time or when REGEN. DAYS preset has passed. Which ever occurs first.
Regen. Time		This setting controls the time of day when a regeneration will start.
Water Usage		This setting is the water usage of average of months.
Water Capacity		This setting is the total water volume the system can treat after one complete regeneration.
Resin Volume		This setting is the amount of ion exchange media used in the system. The value is used to calculate system capacity and refill time.
Salt Amount		This setting will determine the salt dosage used per regeneration.
Refill Flow Rate		This value should match the BLFC flow washer. It is used to calculate the refill time.
Salt Efficiency		This setting is the amount of capacity which a certain amount of salt can restore. The value is used to calculate system capacity and refill time.
Reserve Capacity		This value is used to calculate the reserve capacity. Reserve Capacity = No. People x Daily Reserve.
Regen. Cycle	Backwash	Control the backwash duration during regeneration cycle.
	Brine	Control the brine duration during regeneration cycle.
	Rinse	Control the rinse duration during regeneration cycle.
	Refill	Control the refill duration during regeneration cycle.
Restore Defaults		Restore settings to the factory default.
Pre-Fill		If the brine Pre-Fill is ON, the percentage of water pre-set that will be added to the brine tank after a regeneration. The default is 70%. The remaining amount of water will be added just prior to the regeneration and will be proportional to the amount of capacity left in the system.
Chlorine		When the system is equipped with chlorine generator, switch it ON to activate the chlorine generator during regeneration.
Salt Check		Softener will check the salt level in the brine tank automatically, in the event of system short of salt, display will beep to remind you to add salt.

SYSTEM INFORMATION PAGE

When you enter system information setting, system key information can be viewed in this page.

 System Information Total Regenerations 0 Times  	 System Information Total Treated Water 0 Gallons  	 System Information Regeneration Time 02:00 AM  
 System Information Water Capacity 01050 Gallons  	 System Information Capacity Remaining 01050 Gallons  	 System Information Backwash Time 15 Minutes  
 System Information Brine Time 50 Minutes  	 System Information Rinse Time 10 Minutes  	 System Information Refill Time 02.7 Minutes  
 System Information Current Flow Rate 00.00 GPM  	 System Information Peak Flow Rate 00.00 GPM  	 System Information Software Version V1.0  

NOTE: In “Total Regenerations”, “Total Treated Water” and “Peak Flow Rate” page, press and hold “CONFIRM” button for 3 seconds will reset the value to zero.

OPERATION DURING A POWER FAILURE

In the event of a power failure, the valve will keep track of the time and day. The programmed settings are stored in a non-volatile memory and will not be lost during a power failure. If power fails while the unit is in regeneration, the valve will finish regeneration from the point it is at once power is restored. If the valve misses a scheduled regeneration due to a power failure, it will queue a regeneration at the next regeneration time once power is restored.

START-UP INSTRUCTIONS

1. Add two liters of water into the cabinet at the time of installation. This is for the unit to achieve proper capacity in the first time of regeneration.
2. Plug the power transformer into an approved power source. Connect the power cord to the valve.
3. When power is supplied to the control, the screen will may display "Advancing to Service Wait Please" while it finds the service position.

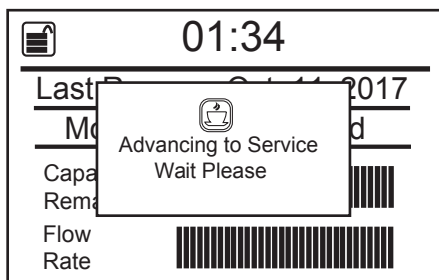

4. Manually step the valve to the BACKWASH position. If screen is locked, the screen will display "Key Locked, Press and Hold "MENU" key for 3 Seconds to Unlock". Follow the instructions below to step the valve to BACKWASH position. As the valve arrives at BACKWASH position, unplug the power and let valve stay at BACKWASH position.

- 4.1 Press and hold MENU key for 3s to unlock.

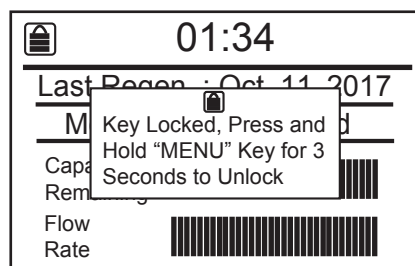

- 4.2 Press and hold CONFIRM key for 3s to advance to MANUAL REGEN menu.

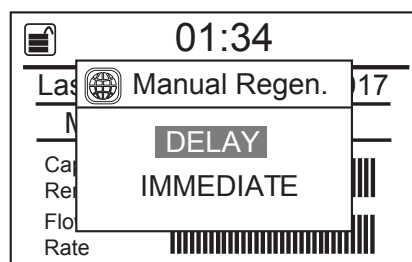

- 4.3 Press CONFIRM key again to let the option flash.

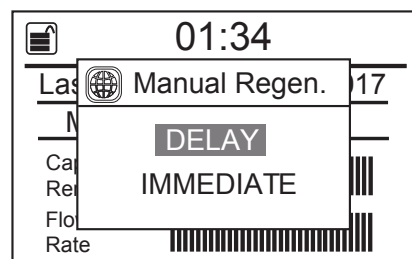

- 4.4 Press DOWN key to advance to IMMEDIATE option.

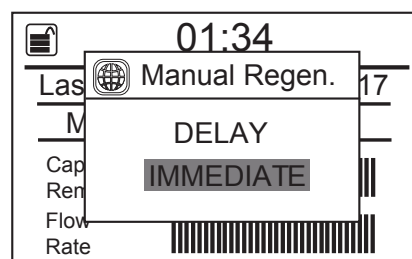

- 4.5 Press CONFIRM key to confirm and press MENU key to have a manual regeneration.

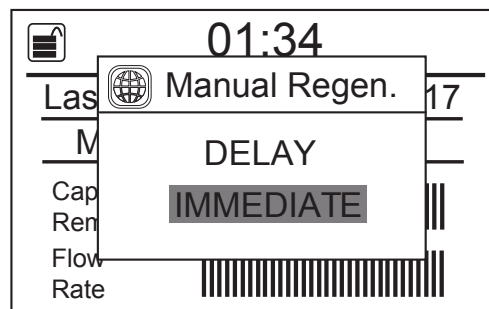

NOTE: If you select "DELAY" option, the valve will start to regenerate at the closest day's REGEN. TIME (default is 02:00)

5. Slowly open the inlet knob on the bypass valve with the bypass tool supplied and allow water to enter the unit. Allow all air to escape from the unit before turning the bypass fully open. Then allow water to run to drain for 3-4 minutes or until all media fines are washed out of the conditioner indicated by clear water in the drain hose. Open a cold soft water tap nearby and let water run a few minutes or until the system is free of foreign material resulting from the plumbing work. Close the water tap when water runs clean.

6. Press any button to advance to the BRINE position, when it arrives, press any key to skip the BRINE cycle. Press any button to advance to the RINSE position. Check the drain line flow. Allow the water to run for 3-4 minutes or until the water is clear.

7. Press any button to advance to the REFILL position. Check that the valve is filling water into the brine tank. Allow the valve to refill for the full amount of time as displayed on the screen to insure a proper brine solution for the next regeneration.

8. The valve will automatically advance to the SERVICE position. Open the outlet knob on the bypass with the bypass tool supplied. With the bypass open, open the nearest treated water faucet and allow the water to run until clear.

9. Add salt into the cabinet. Put 40 kgs of crystal water softener salt in the 1035 softener cabinet or 15kgs of crystal water softener salt in the 1015 softener cabinet. The unit will automatically fill the water to the correct level when it regenerates.

10. Program unit.

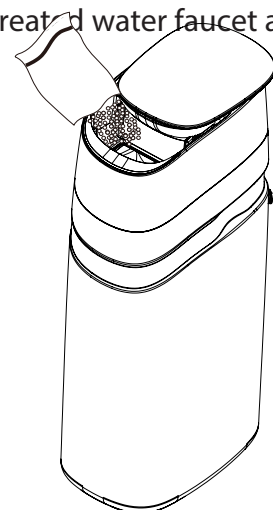

CAUTION

LIQUID BRINE WILL IRRITATE EYES, SKIN AND OPEN WOUNDS - GENTLY WASH EXPOSED AREA WITH FRESH WATER. KEEP CHILDREN AWAY FROM YOUR WATER CONDITIONER.

AUTOMATIC RAW WATER BYPASS DURING REGENERATION

The regeneration cycle can last 60 minutes after which Softened water service will be restored. During regeneration, un-Softened water is automatically bypassed for use in the household. Hot water should be used as little as possible during this time to prevent un-Softened water from filling the water heater. This is why automatic regeneration is set for sometime during the night and manual regenerations should be performed when little or no water will be used in the household.

MAINTENANCE INSTRUCTIONS

CHECK THE SALT LEVEL

Check the salt level monthly. Remove the lid from the cabinet or brine tank, make sure salt level is always above the brine level.

NOTE

YOU SHOULD NOT BE ABLE TO SEE WATER IN THE CABINET OR BRINE TANK.

ADDING SALT

Use only clean salt labeled for water conditioner use, such as crystal, pellet, nugget, button or solar. The use of rock salt is discouraged because it contains insoluble silt and sand which build up in the brine tank and can cause problems with the system's operation. Add the salt directly to the tank, filling no higher than the top of the brine well.

BRIDGING

Humidity or the wrong type of salt may create a cavity between the water and the salt. This action, known as "bridging", prevents the brine solution from being made, leading to your water supply being hard.

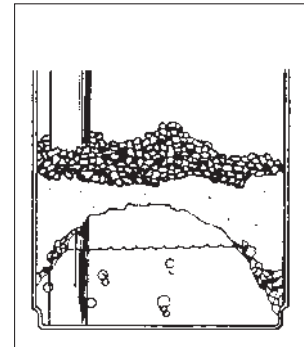

If you suspect salt bridging, carefully pound on the outside of the plastic cabinet or pour some warm water over the salt to break up the bridge. This should always be followed up by allowing the unit to use up any remaining salt and then thoroughly cleaning out the cabinet. Allow four hours to produce a brine solution, then manually regenerate the softener.

Resin Cleaner

An approved resin cleaner must be used on a regular basis if your water supply contains iron. The amount of resin cleaner and frequency of use is determined by the quantity of iron in your water (consult your local representative or follow the directions on the resin cleaner package).

Care of Your Water Conditioner

To retain the attractive appearance of your new water conditioner, clean occasionally with a mild soap solution. Do not use abrasive cleaners, ammonia or solvents. Never subject your conditioner to freezing.

SERVICE THE BNT850SE CONTROL VALVE



CAUTION

Disassembly while under pressure can result in flooding. Always follow these steps prior to servicing the valve.



WARNING



Electrical shock Hazard! unplug the unit before removing the cover or accessing any internal control parts.

Before Servicing

1. Turn off water supply to conditioner using the bypass tool attached on the bypass.

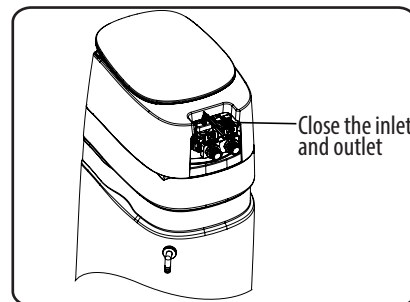
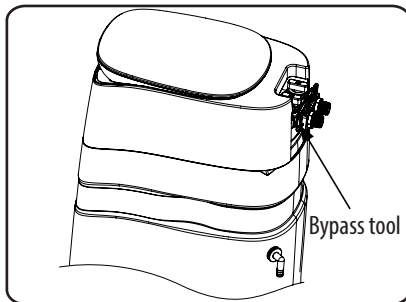

2. Relieve water pressure in the conditioner by stepping the control into the backwash position momentarily. Return the control to the In Service position.
3. Unplug electrical cord from outlet.
4. Disconnect drain line connection.

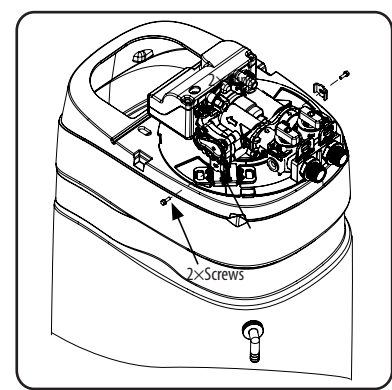
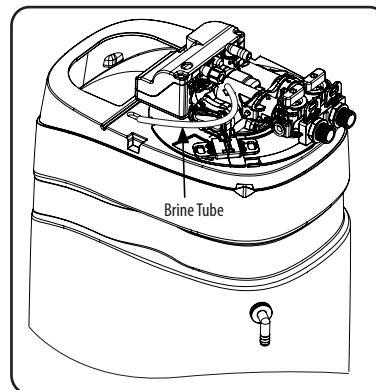
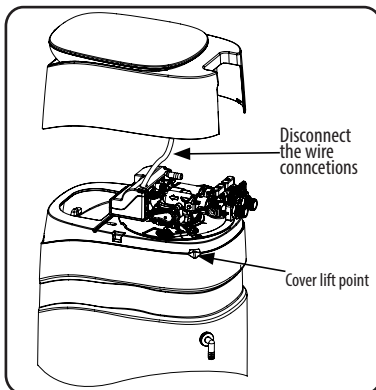

5. Remove the cover and disconnect the wire connection.
6. Disconnect the brine line.
7. Remove the clips that connect control valve and bypass.

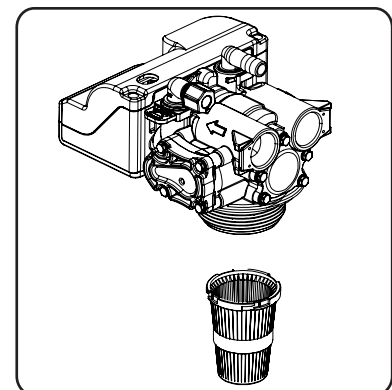
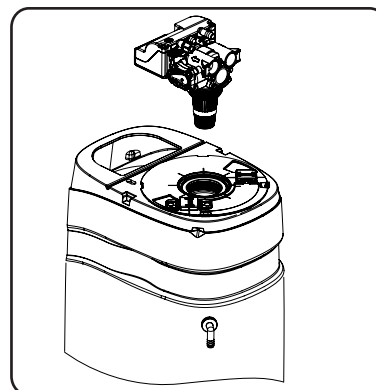
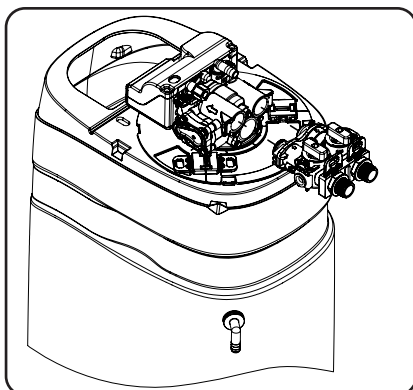

8. Disconnect the softener from the bypass.
9. Remove the valve from the softener.
10. Remove the top cone from the valve.

REPLACE TIMER

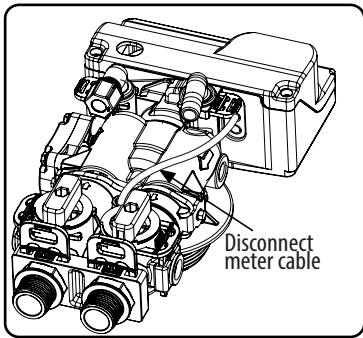

1. Disconnect the meter cable from the meter. (If meter cable is attached).

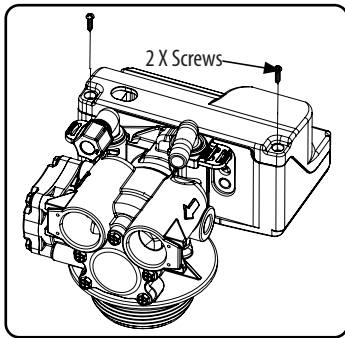

2. Remove the two screws from the valve cover.

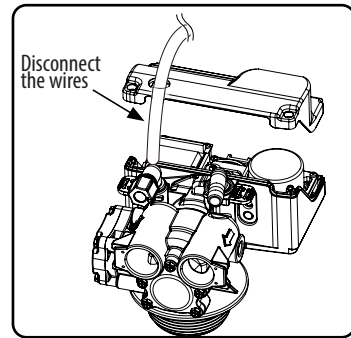

3. Remove the cover of the valve and disconnect the wires attached on PCB.

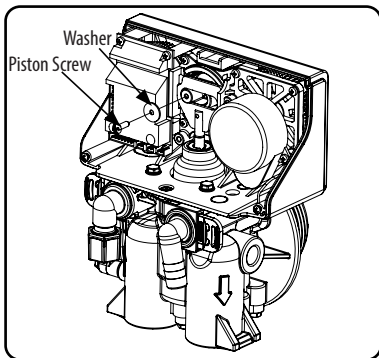

4. Remove the piston screw and washer from the piston rod.

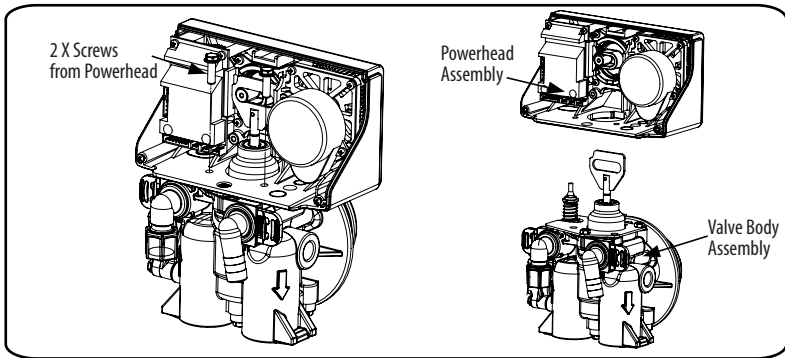

5. Remove the two screws from the powerhead as shown.

6. Lift the powerhead from the valve body assembly.

7. Replace the powerhead by reverse following the steps in this section.

REPLACE PISTON AND/OR BRINE VALVE

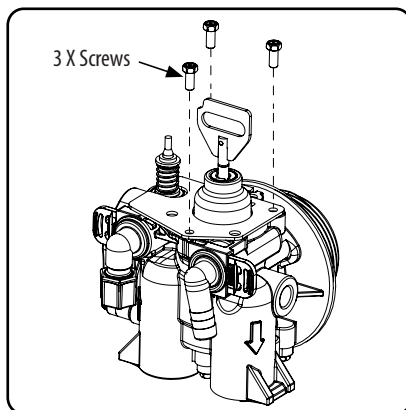

1. Follow steps 1 to 6 of Timer /Powerhead replacement.
2. Remove three screws from the plate on the valve body.

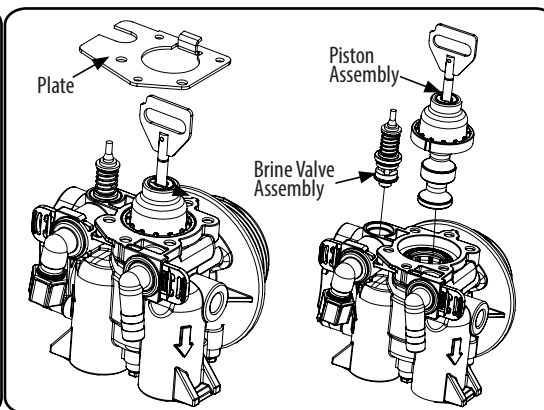

3. Remove the plate from the valve body and pull the Piston Assembly from the valve. The brine valve assembly can also be removed in this stage.

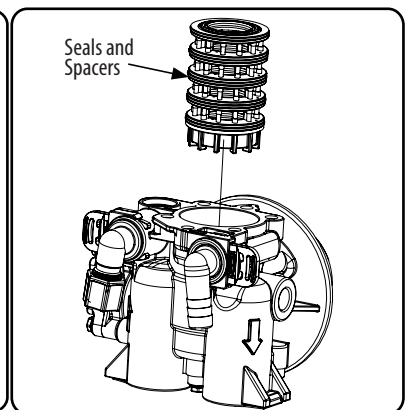

4. Remove the seals and spacers assembly, grease it with silicone lubricant and put back in.

5. After servicing, reverse following steps in this section.

REPLACE SEAL AND/OR SPACER

REPLACE METER

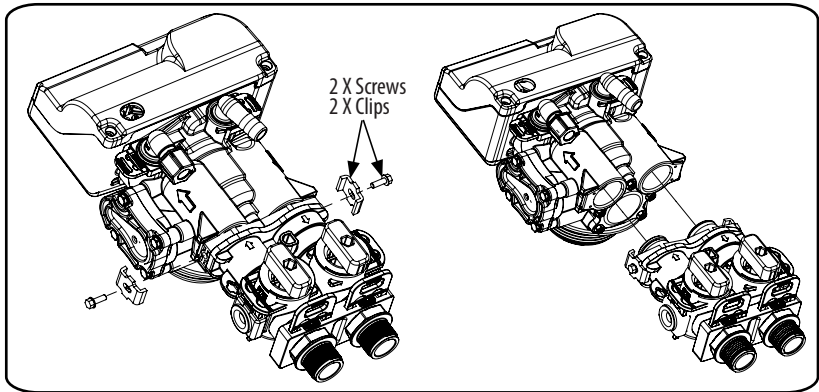
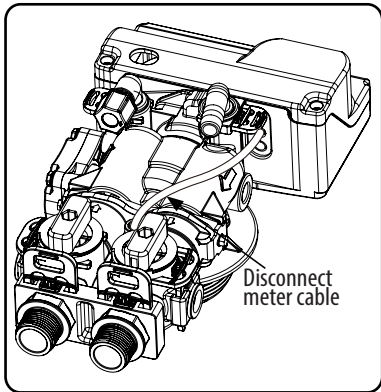

1. Disconnect the meter cable from the meter. (If flow meter cable is attached)
2. Disconnect the bypass from valve by removing clips.

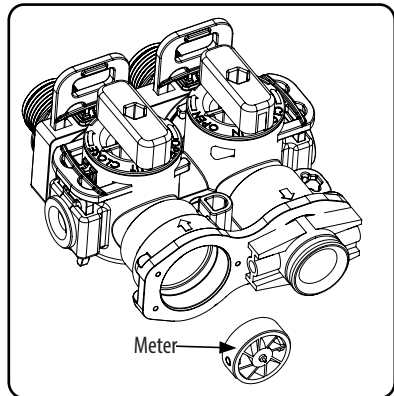
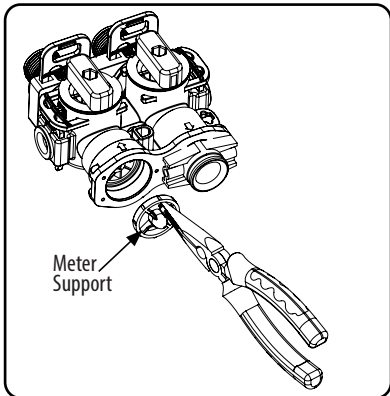
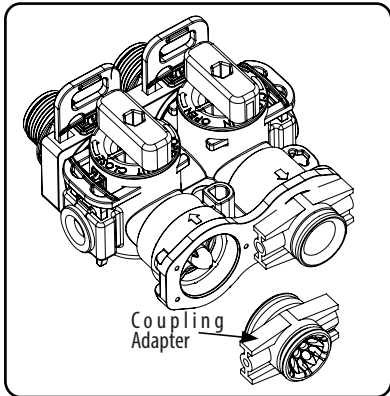

3. Remove the coupling adapter from the bypass.
4. Remove the meter support from the bypass.
5. Remove the impeller and replace it. (Watch for the meter ball under the impeller, do not miss the ball)

CLEAN INJECTOR ASSEMBLY

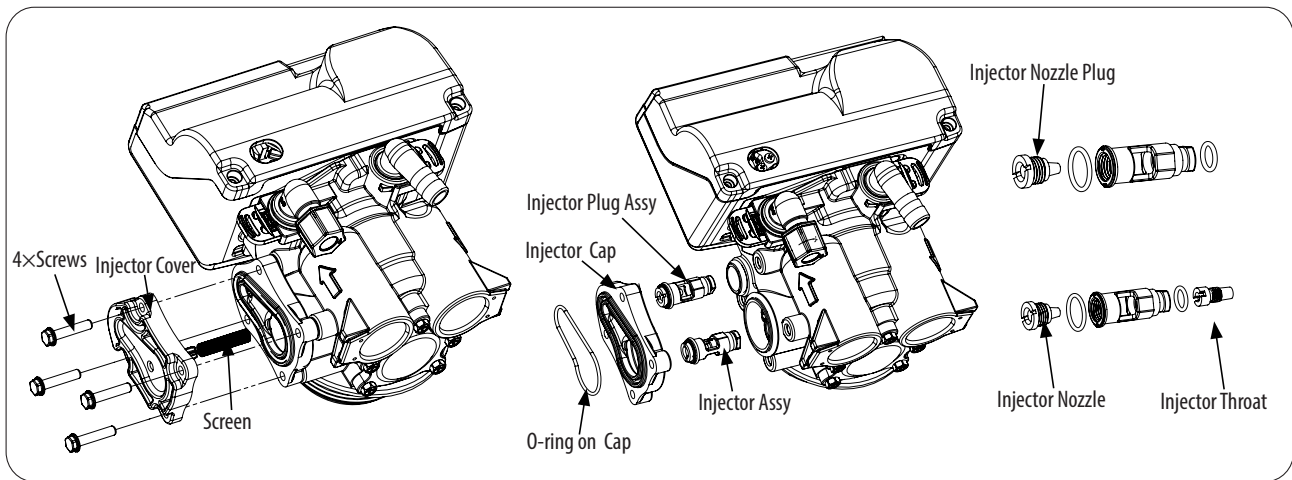

1. Remove the four screws on the injector cover.
2. Pull the injector cover out, watch for the screen and o-ring.
3. Pull the injector cap out, pull the injector assy and injector plug assy out.
4. Screw the injector nozzle and injector throat out, clean and replace it.
5. After servicing, reverse following steps in this section.

REPLACE DRAIN LINE FLOW CONTROL

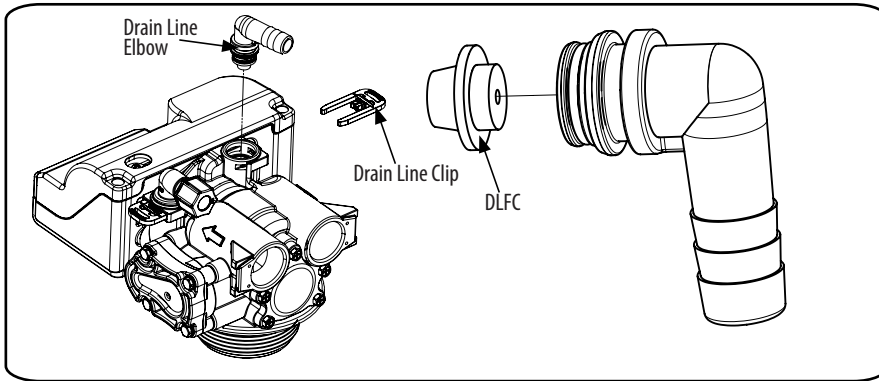

1. Pull the drain line clip and remove the drain line elbow and washer.
2. Clean/replace drain line flow control.

REPLACE BRINE LINE FLOW CONTROL

1. Pull the brine line clip and remove the brine line elbow Assy.
2. Remove the BLFC holder.
3. Take out the BLFC, clean/replace the BLFC button.

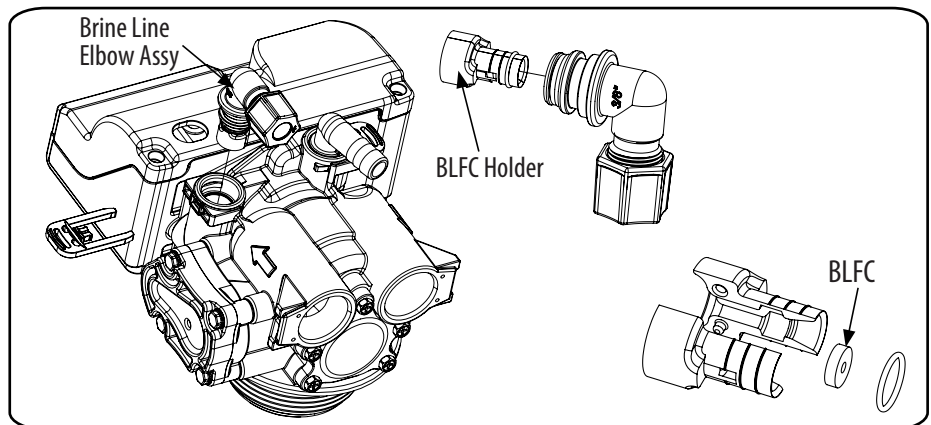

REPLACE MOTOR

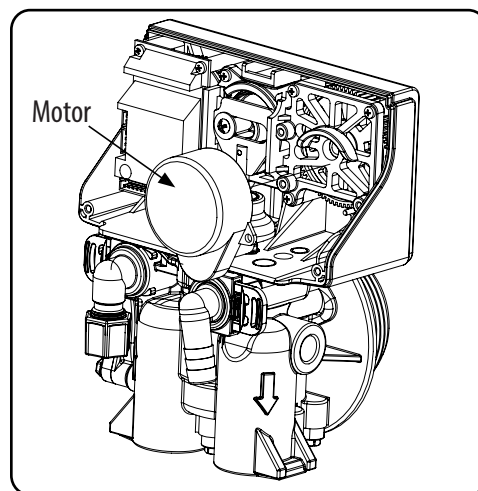
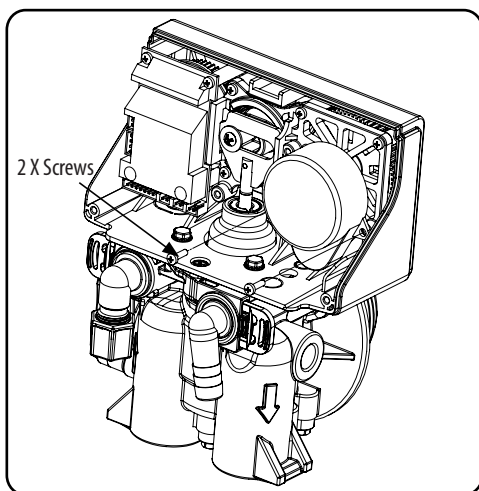

1. Follow steps 1 to 3 of Timer /Powerhead replacement.
2. Remove the two screws from the motor. Remove motor(disconnect the wire attached on PCB if any), watch for the pin under the motor.
3. Replace the motor.

REPLACE CIRCUIT BOARD

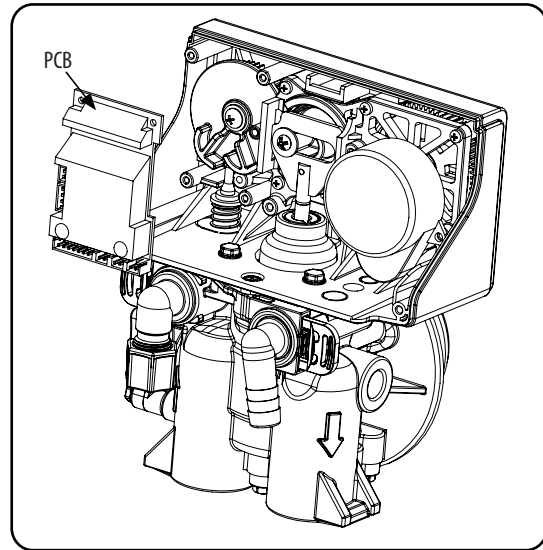
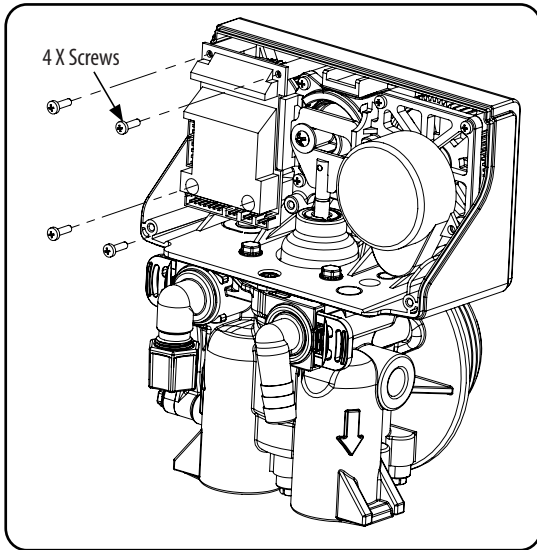

1. Follow steps 1 to 3 of timer /Powerhead replacement.
2. Remove all the connections on PCB.
3. Remove the four screws from the PCB.
4. Replace the PCB.

REPLACE DISPLAY

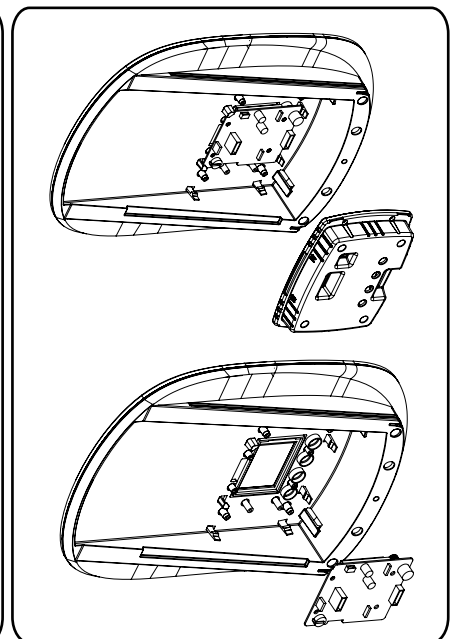
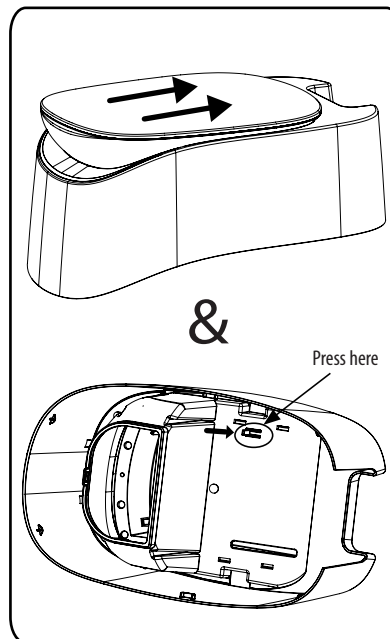
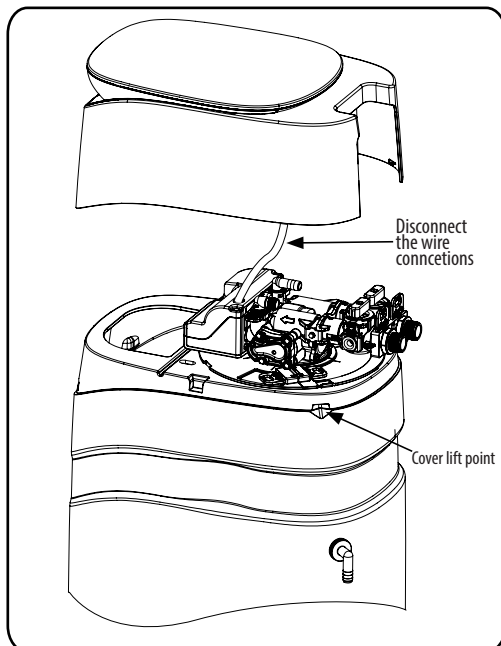

1. Remove the cover from the cabinet.
2. Disconnect the wire connection.
3. Slide the cover as the arrow indicate, as it reaches the end, press the snap clip simultaneously as the arrow indicate to remove the glass panel from high cover.
4. Remove the display back cover from the glass panel. (No screws attached on)
5. Remove the display from the glass panel. (No screws attached on)
6. Replace the display.

TROUBLE SHOOTING GUIDE

Problem	Possible Solutions
<p>1. CONDITIONER DELIVERS HARD WATER</p> <p>A. Bypass valve is open B. No salt in brine tank C. Injector or screen plugged D. Insufficient water flowing into brine tank E. Leak at distributor tube F. Internal valve leak G. Flow meter jammed H. Flow meter cable disconnected or not plugged into meter cap I. Improper programming</p>	<p>A. Close bypass valve B. Add salt to brine tank and maintain salt level above water level C. Replace injectors and screen D. Check brine refill time and clean brine line flow control if plugged E. Make sure distributor tube is not cracked. Check O ring and tube pilot F. Replace seals and spacers and/or piston G. Remove obstruction from flow meter H. Check meter cable connection to timer and meter cap I. Reprogram the control to the proper regeneration type, inlet water hardness, capacity or flow meter size.</p>
<p>2. CONDITIONER FAILS TO REGENERATE</p> <p>A. Electrical service to unit has been interrupted B. Timer is not operating properly C. Defective valve drive motor D. Improper programming</p>	<p>A. Assure permanent electrical service (check fuse, plug, chain or switch) B. Replace timer C. Replace drive motor D. Check programming and reset as needed</p>
<p>3. UNIT USES TOO MUCH SALT</p> <p>A. Improper salt setting B. Excessive water in brine tank C. Improper programming</p>	<p>A. Check salt usage and salt setting B. See #7 C. Check programming and reset as needed</p>
<p>4. LOSS OF WATER PRESSURE</p> <p>A. Iron build-up in line to water conditioner B. Iron build-up in water conditioner C. Inlet of control plugged due to foreign material broken loose from pipes by recent work done on plumbing system.</p>	<p>A. Clean line to water conditioner B. Clean control and add resin cleaner to resin bed. Increase frequency of regeneration C. Remove piston and clean control</p>
<p>5. LOSS OF RESIN THROUGH DRAIN LINE</p> <p>A. Air in water system B. Drain line flow control is too large</p>	<p>A. Assure that well system has proper air eliminator control. Check for dry well condition. B. Ensure drain line flow control is sized</p>
<p>6. IRON IN CONDITIONED WATER</p> <p>A. Fouled resin bed B. Iron content exceeds recommended parameters</p>	<p>A. Check backwash, brine draw and brine tank fill. Increase frequency of regeneration. Increase backwash time. B. Add iron removal filter system</p>
<p>7. EXCESSIVE WATER IN BRINE TANK</p> <p>A. Plugged drain line flow control B. Brine valve failure C. Improper programming</p>	<p>A. Clean flow control B. Replace brine valve C. Check programming and reset as needed</p>
<p>8. SALT WATER IN SERVICE LINE</p> <p>A. Plugged injector system B. Timer not operating properly C. Foreign material in brine valve D. Foreign material in brine line flow control E. Low water pressure F. Improper programming</p>	<p>A. Clean injector and replace screen B. Replace timer C. Clean or replace brine valve D. Clean brine line flow control E. Raise water pressure F. Check programming and reset as needed</p>
<p>9. CONDITIONER FAILS TO DRAW BRINE</p> <p>A. Drain line flow control is plugged B. Injector is plugged C. Injector screen is plugged D. Line pressure is too low E. Internal control leak F. Improper programming G. Timer not operating properly</p>	<p>A. Clean drain line flow control B. Clean or replace injectors C. Replace screen D. Increase line pressure (line pressure must be at least 20 psi at all times) E. Change seals and spacers and/or piston assembly F. Check programming and reset as needed G. Replace timer</p>
<p>10. CONTROL CYCLES CONTINUOUSLY</p> <p>A. Timer not operating properly B. Faulty microswitches and/or harness C. Faulty cycle cam operation</p>	<p>A. Replace timer B. Replace faulty microswitch or harness C. Replace cycle cam or reinstall</p>
<p>11. DRAIN FLOWS CONTINUOUSLY</p> <p>A. Foreign material in control B. Internal control leak C. Control valve jammed in backwash, brine or rinse position D. Timer motor stopped or jammed teeth E. Timer not operating properly</p>	<p>A. Remove piston assembly and inspect bore. Remove foreign material and check control in various regeneration positions B. Replace seals and/or piston assembly C. Replace piston and seals and spacers D. Replace timer motor and check all gears for missing teeth E. Replace timer</p>

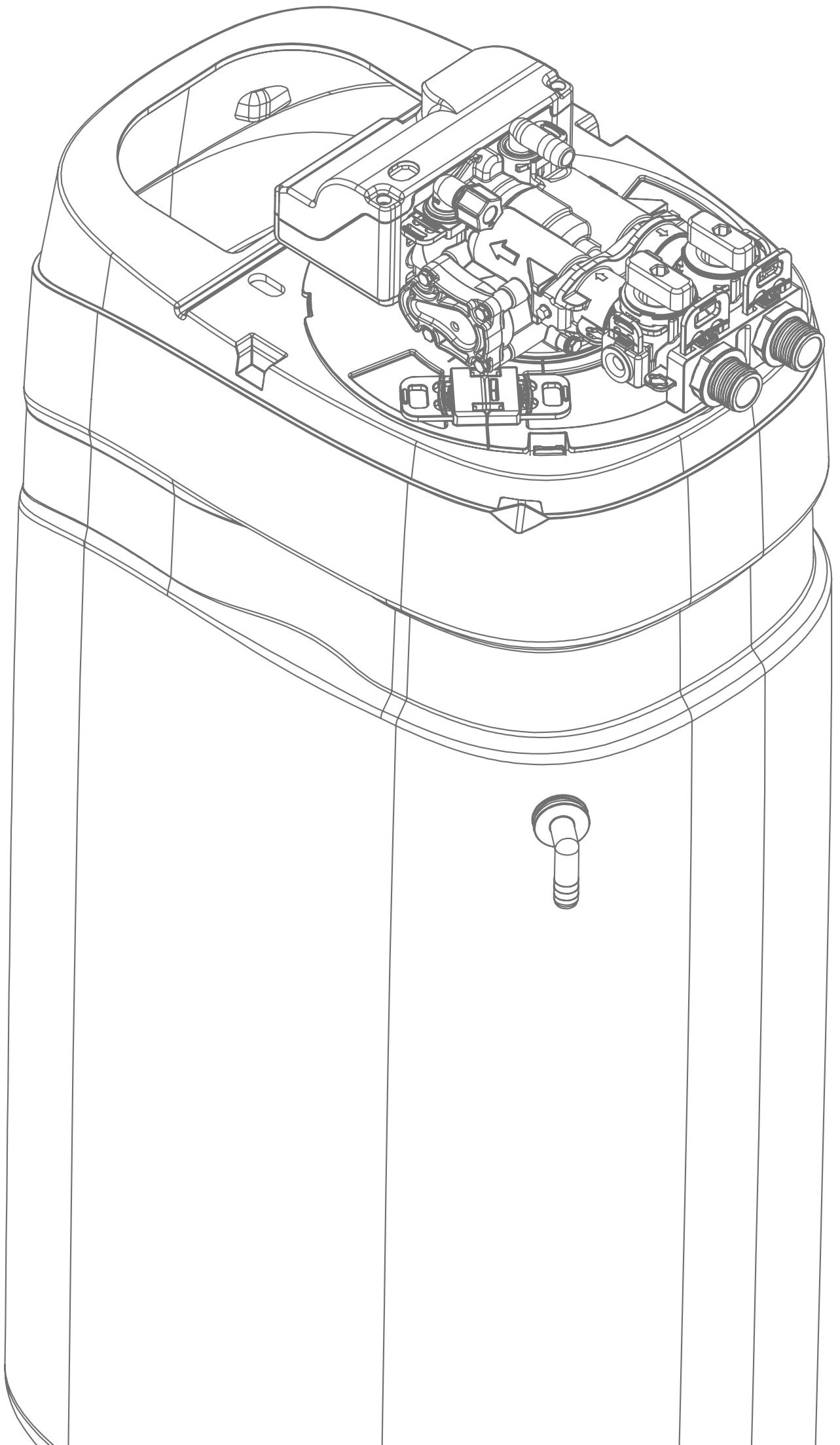



Division of ATLAS FILTRI ITALIA S.r.l.

Via Unità d'Italia, 12 - I-35010 LIMENA (PD) Italy - Tel +39.049.88.41.410 - Fax +39.049.884.52.94 - info@atlasfiltriengineering.com

www.atlasfiltriengineering.com

Images and texts are property of ATLAS FILTRI srl, which reserves the rights to change products design and specification without prior notice.